

**COMPREHENSIVE GROUND MAINTENANCE – TOWSON UNIVERSITY NORTHEAST (T.U.N.E)****TU 2412-SBR**

**This is a Small Business Reserve Procurement for which award will be limited to Certified Small Business vendors. Only businesses that meet the statutory requirements set forth in State Finance and Procurement Article, §§ 14-501 - 14-505, Annotated Code of Maryland, and who are registered with the Governor's Office of Small, Women, General Services Small Business Reserve Program are eligible for award of a contract.**

Prospective bidders/offerors who obtained this document from the university's website, e-Maryland Marketplace, or any source other than the procurement officer, should provide their names and email addresses to the issuing office by contacting (410) 704-2171, to ensure receipt of addenda and other communications regarding the solicitation.

**ISSUING OFFICE**

Procurement Department  
8000 York Road  
Towson, MD 21252-0001

**PROCUREMENT OFFICE LOCATION**

Administration Building  
7720 York Road, 4<sup>th</sup> Floor  
Towson, MD 21204

**KEY INFORMATION SUMMARY SHEET**

**COMPREHENSIVE GROUND MAINTENANCE – TOWSON UNIVERSITY NORTHEAST (T.U.N.E)**

**PROJECT NO. TU-2412**

**IFB ISSUE DATE:** November 9, 2023

**IFB ISSUING OFFICE:** Towson University Procurement Office

**PROCUREMENT OFFICER REPRESENTATIVE:** Name: Joselyn M. Johnson  
Phone: 410-704-4453  
Email: [jmjohnson@towson.edu](mailto:jmjohnson@towson.edu)

**PROCUREMENT OFFICE LOCATION:** Towson University  
Procurement Department  
Administration Building, 4<sup>th</sup> Floor  
7720 York Road  
Towson, MD 21204

**PRE-BID/PROPOSAL CONFERENCE:** 11/13/2023 – 10:00AM – 1<sup>st</sup> site visit immediately following Pre-Bid/Proposal Conference, Towson University Northeast Location 510 Thomas Run Road Room 212 Belair, MD 21015

**SECOND SITE VISIT:** NOTE: Attendance at one (1) site visit is mandatory  
11/15/2023 – 10:00AM- 2<sup>nd</sup> site visit immediately following Pre-Bid/Proposal Conference, Towson University Northeast Location 510 Thomas Run Road Room 212 Belair, MD 21015

**DEADLINE FOR QUESTIONS:** November 28, 2023 – 4:30PM

**BIDS DUE** (Public Bid Opening): December 11, 2023– 2:00PM

**CONTRACT TERM:** One year with four (4) one year renewal options at the discretion of the University beginning on or about January 1, 2024.

The University is committed to ensuring that persons with disabilities have equally effective opportunities to participate in and benefit from the University's programs and services. Persons who may require reasonable ADA accommodations should contact the Issuing Office at 410-704-2171 at least five (5) days prior to any meeting scheduled in connection with this solicitation.

## NOTICE TO BIDDER/OFFERORS

To help improve the quality of bid and proposal solicitations and to make our procurement process more responsive and "business friendly," we ask that you provide comments and suggestions regarding the enclosed solicitation. Please return your comments with your bid, proposal or "no bid," response, as the case may be. Thank you for your assistance.

Project No.: \_\_\_\_\_ Project Title: \_\_\_\_\_

If you have responded with a "no bid" please indicate the reasons below (check applicable boxes):

- Other commitments preclude our participation at this time.
- The subject of the solicitation is not something we normally provide.
- We are inexperienced in the work/commodities required.
- The specifications are either unclear or too restrictive (explain below).
- The scope of work is beyond our current capacity.
- Doing business with Maryland Government Agencies is simply too complicated (explain below).
- We cannot be competitive (explain below).
- Time allotted for completion of the bid/proposal response is insufficient.
- Start-up time is insufficient.
- Bonding/insurance requirements are prohibitive (explain below).
- MBE requirements (explain below).
- Bid/Proposal requirements (other than specifications or scope) are unreasonable or too risky (explain below)
- Prior experience with Towson University contracts were not profitable or otherwise unsatisfactory (explain below).
- Payment schedule too slow.
- Other: \_\_\_\_\_

Explanation: \_\_\_\_\_  
\_\_\_\_\_  
\_\_\_\_\_

If you have submitted a bid or proposal, but wish to offer suggestions or express concerns, please use the remarks section below:

Remarks: \_\_\_\_\_  
\_\_\_\_\_

Bidder/Offeror Name: \_\_\_\_\_

Contact Person: \_\_\_\_\_

Signature: \_\_\_\_\_ Date: \_\_\_\_\_

Address: \_\_\_\_\_

Email: \_\_\_\_\_ Phone: \_\_\_\_\_

**NOTICE TO BIDDERS**

**SMALL BUSINESS RESERVE PROCUREMENT**

This is a Small Business Reserve Procurement for which award will be limited to Certified Small Business vendors. Only businesses that meet the statutory requirements set forth in State Finance and Procurement Article, §§ 14-501 - 14-505, Annotated Code of Maryland, and who are registered with the Governor's Office of Small, Minority and Women Business Affairs' Small Business Reserve Program are eligible for award of a contract.

For the purposes of a Small Business Reserve Procurement, a small business is a business, other than a broker, that meets the following criteria:

- ❖ **The business is independently owned and operated;**
- ❖ **The business is not a subsidiary of another business;**
- ❖ **The business is not dominant in its field of operation;**
- ❖ **The wholesale operations of the business did not employ more than 50 persons, or the gross sales of the business did not exceed an average of \$4,000,000 in its most recently completed 3 fiscal years;\***
- ❖ **The retail operations of the business did not employ more than 25 persons, or the gross sales of the business did not exceed an average of \$3,000,000 in its most recently completed 3 fiscal years;\***
- ❖ **The manufacturing operations of the business did not employ more than 100 persons, or the gross sales of the business did not exceed an average of \$2,000,000 in its most recently completed 3 fiscal years;\***
- ❖ **The service operations of the business did not employ more than 100 persons, or the gross sales of the business did not exceed an average of \$10,000,000 in its most recently completed 3 fiscal years;\*** and
- ❖ **The construction operations of the business did not employ more than 50 persons, or the gross sales of the business did not exceed an average of \$7,000,000 in its most recently completed 3 fiscal years.\***
- ❖ **The architectural and engineering services of the business did not employ more than 100 persons or the gross sales of the business did not exceed an average of \$4,500,000 in its most recently completed 3 fiscal years.**

**\*If a business has not existed for three years, the gross sales average shall be the average for each year or part of a year during which the business has been in existence.**

Further information on the certification/registration process is available at [e-Maryland Marketplace Advantage](#).

**SECTION I. INFORMATION FOR BIDDERS..... 1**

A. SUMMARY STATEMENT..... 1

B. ISSUING OFFICE AND PROCUREMENT OFFICER ..... 1

C. PRE-BID CONFERENCE..... 1

D. QUESTIONS AND INQUIRIES..... 1

E. SITE INVESTIGATION..... 1

F. INSURANCE ..... 1

G. BID SECURITY ..... 2

H. BID DUE DATE..... 3

I. OPENING OF BIDS..... 3

J. DURATION OF BID OFFER..... 3

K. PROCUREMENT METHOD ..... 3

L. AWARD ..... 3

M. MULTIPLE BID OR ALTERNATE BIDS..... 3

**SECTION II. GENERAL INFORMATION FOR BIDDERS ..... 4**

A. PURPOSE..... 4

B. REVISIONS TO IFB ..... 4

C. PRE-BID MODIFICATION OR WITHDRAWAL OF OFFERS..... 4

D. CANCELLATION OF SOLICITATION/REJECTION OF ALL BIDS ..... 4

E. INCURRED EXPENSES ..... 4

F. ARREARAGES..... 4

G. VERIFICATION OF REGISTRATION AND TAX PAYMENT..... 4

H. ECONOMY OF PREPARATION ..... 4

I. PUBLIC INFORMATION ACT NOTICE ..... 4

J. EXECUTION OF BIDS ..... 4

K. DISCREPANCIES, EXPLANATIONS AND CLARIFICATIONS ..... 5

L. ORDER OF PRECEDENCE..... 5

M. REQUIRED CONTRACT PROVISIONS..... 5

N. FALSE STATEMENTS ..... 5

O. PAYMENT TO THE CONTRACTOR ..... 6

P. VENDOR ELECTRONIC FUNDS TRANSFER REGISTRATION ..... 6

Q. RECIPROCAL PREFERENCE..... 6

R. NON-VISUAL ACCESS ..... 6

S. INTERGOVERNMENTAL COOPERATIVE PURCHASING .....	6
T. PARKING.....	6
U. SMOKING.....	7
V. POLLINATOR PROTECTION ACT OF 2016.....	7
W. ENVIRONMENTALLY PREFERENCE PURCHASING .....	7
X. MARYLAND’S GREEN PURCHASING REPORTING REQUIREMENTS .....	7
Y. ENVIRONMENTAL CLAIMS .....	7
<b>SECTION III. BID SUBMISSION REQUIREMENTS .....</b>	<b>8</b>
A. ORGANIZATION OF BIDS.....	8
B. SUBMITTAL REQUIREMENTS CHECKLIST .....	8
C. CONTRACT AFFIDAVIT.....	8
D. EVIDENCE OF BIDDER RESPONSIBILITY .....	9
<b>SECTION IV. BID SUBMISSION REQUIREMENTS .....</b>	<b>10</b>
A. ORGANIZATION OF BIDS.....	10

EXHIBITS

EXHIBIT A-1 – Environmental Health and Safety Requirements
EXHIBIT A-2 – Required Contract Provisions for Construction and Maintenance
EXHIBIT B – Bid/Proposal Affidavit
EXHIBIT C – Contract Affidavit
EXHIBIT D – Sample Agreement
EXHIBIT E – N/A
EXHIBIT F – Company Profile
EXHIBIT G – Firm Experience
EXHIBIT H – Bid Bond
EXHIBIT I – Performance Bond
EXHIBIT J – Payment Bond
EXHIBIT K – Addenda Acknowledgment
EXHIBIT L – Key Personnel Form
EXHIBIT M- Mowing Exhibit
EXHIBIT N- Planning Details & Notes
EXHIBIT O- Planting Plan
EXHIBIT P- Bid/Price Proposal Form
TU-2412 Bid Worksheet (Excel)

## SECTION I. INFORMATION FOR BIDDERS

### A. SUMMARY STATEMENT

Towson University (TU or University) is seeking an experienced certified small business contractor to provide comprehensive landscape site maintenance for Towson University Northeast Campus, Harford County (T.U.N.E.) in accordance with this Solicitation.

### B. ISSUING OFFICE AND PROCUREMENT OFFICER

The sole point of contact in the State for purposes of this IFB is the Procurement Officer or his/her representative (hereinafter referred to as Procurement Officer) noted on the Key Information Summary Sheet. Only the information communicated by the Procurement Officer shall be deemed the official position of the University; no other State or University employee, official, or representative has authority to change the requirements of this solicitation. Attempts by Bidder to contact the requester, evaluator, or otherwise circumvent this procedure in any manner may be grounds for disqualification.

### C. PRE-BID CONFERENCE AND SITE VISIT

1. Prior to submitting its bid, each contractor is encouraged to attend the scheduled pre-bid conference to examine the facility and familiarize himself with the full nature and extent of the work to be done. They shall obtain for themselves all information that may be necessary for the satisfactory performance of the contract work and the cost thereof. It is the sole responsibility of the contractor to fully familiarize themselves with the areas involved and the extent of the services required by visual inspection. Failure to visit the site and become familiar with the conditions and requirements affecting the work will not relieve the successful contractor from the provisions of the contract and from completing the work for the consideration set forth.
2. Two (2) site visits are scheduled and listed on the Key Information Summary Sheet. **Please note: in order to be considered for award one (1) site visit is mandatory.**
3. Towson University is committed to ensuring that persons with disabilities are given an equally effective opportunity to participate in and benefit from the university's programs and services. Persons with disabilities who might need reasonable accommodations should contact the Procurement Department at least 72 hours before any meetings held in connection with this solicitation at (410) 704-2171.

### D. QUESTIONS AND INQUIRIES

Bidders shall direct all communications regarding this solicitation to the Procurement Officer, in writing (email preferred), not later than the date indicated on the Key Information Summary Sheet. Addenda, if required, will be furnished to all potential Bidders known to have received the IFB.

### E. SITE INVESTIGATION

By submitting a bid the vendor acknowledges that he has investigated and satisfied himself as to the conditions affecting the work, including but not restricted to those bearing upon transportation, disposal, handling and storage of materials, availability of labor, water, and electric power. Any failure by the contractor to acquaint himself with the available information will not relieve him from responsibility for estimating properly the cost of successfully performing the work. The University shall not be responsible for any conclusions or interpretations made by the contractor of the information made available by the University.

### F. INSURANCE

1. The Bidder shall secure, pay the premiums for, and keep in force until the expirations of the contract, and any renewal thereof, adequate insurance as provided below, such insurance to

specifically include liability assumed by the Bidder under the contract. Upon award, the successful Bidder shall furnish certificates of insurance.

- a. Commercial General Liability Insurance including all extensions; \$2,000,000 each occurrence; \$2,000,000 personal injury; \$2,000,000 products/completed operations; and \$2,000,000 general aggregate.
  - b. Workmen's Compensation Insurance and Unemployment Insurance as required by the laws of the State of Maryland.
  - c. If automotive equipment is used in the operation, automobile liability insurance of \$1,000,000 combined single limit, each accident.
2. Each policy for liability protection, bodily injury or property damage must specifically name, on its face, Towson University, as an additional named insured as respects operations under the contract and premises occupied by the Contractor provided, however, with respect to the Contractor's liability for bodily injury or property damage under items 1.a.-1.e. above, such insurance shall cover and not exclude Contractor's liability for injury to the property of the University System and to the persons or property of employees, students, faculty members, agents, officers, regents, invitees or guests of the University System.
  3. Each insurance policy shall contain the following endorsements: "It is understood and agreed that the Insurance Company shall notify in writing procurement officer forty-five (45) days in advance of the effective date of any reduction in or cancellation of this policy." A certificate of each policy of insurance shall be furnished to the procurement officer. With the exception of Workmen's Compensation, upon the request of the procurement officer, a certified true copy of each policy of insurance, including the above endorsement, manually countersigned by an authorized representative of the insurance company, shall be furnished to the procurement officer. A certificate of insurance for Workmen's Compensation together with a properly executed endorsement for cancellation notice shall also be furnished. Following the notice of contract award, the requested certificates and policies shall be delivered as directed by the procurement officer. Notices of policy changes shall be furnished to the procurement officer.
  4. All required insurance coverages must be acquired from insurers authorized to do business in the State of Maryland and acceptable to the University. The insurers must have a policyholders' rating of "A-" or better, and a financial size of "Class VII" or better in the latest edition of *Best's Insurance Reports*.

#### **G. BID SECURITY**

1. If the total Bid Price is \$100,000.00 or more, each Bidder shall furnish with his bid price a "bid bond" (See Exhibit H) issued by a surety company licensed to issue bonds in the State of Maryland. The bond must be in an amount not less than five percent (5%) of the total amount of the base bid price and shall be in the form specified with the bid documents.
2. Certified checks, cash and other security in that amount are acceptable in lieu of a "bid bond", and shall be submitted with the Bid Price and subject to the same conditions as a bond.
3. Should the Bidder to whom the contract is awarded fail or be unable to execute the contract, for any reason, within ten (10) days after notification of award, then an amount equal to the difference between the accepted price, and that of the bidder to whom the award subsequently is made shall be paid to the University as liquidated damages.
4. The Bidder to whom a contract in excess of \$100,000.00 is awarded also must furnish Performance and Payment Bonds (See Exhibits I and J), each in the amount of one hundred



percent (100%) of the contract price, including executed Change Orders, in the form specified with the bid documents. These must be provided at the time of the signing of the contract and prior to the start of any work.

5. Bid Bonds remain in effect a minimum of ninety (90) days from the bid due date.

**H. BID DUE DATE**

Bids must be received at the Issuing Office by date and time indicated on the Key Information Summary Sheet. Requests for extensions will not be granted. Late bids, late requests for modification, or late requests for withdrawal will not be considered. Unless specifically requested, bids submitted by fax or other electronic devices will be rejected.

**I. OPENING OF BIDS**

A public opening will be held at the date, time and location noted on the Key Information Summary Sheet.

**J. DURATION OF BID OFFER**

Bids submitted are irrevocable for 90 days after the bid due date. This period may be extended by mutual written agreement between the bidder and the University.

**K. PROCUREMENT METHOD**

This solicitation shall be conducted in accordance with the provisions of the *University System of Maryland (USM) Procurement Policies and Procedures*. The procurement method is Competitive Sealed Bidding.

**L. AWARD**

The University will recommend for award a responsive bid from the responsible bidder submitting the most favorable evaluated bid price for the requirement(s) herein.

**M. MULTIPLE BID OR ALTERNATE BIDS**

Unless multiple or alternate bids are specifically requested in the solicitation, they will not be accepted.

**END OF SECTION I**

## SECTION II. GENERAL INFORMATION FOR BIDDERS

### A. PURPOSE

The overall purpose of this solicitation is to provide information to vendors interested in preparing and submitting bids to meet the requirements herein. Bidders shall familiarize themselves with each section and subsection of this document.

### B. REVISIONS TO IFB

1. The University reserves the right to amend this solicitation at any time prior to the bid due date. If it becomes necessary to amend any part of this solicitation, the procurement officer will furnish addenda to all prospective bidders known to have received a copy of this IFB.
2. Each bidder shall acknowledge the receipt of all addenda issued by completing Exhibit K, Addendum Acknowledgment Form, and enclosing it with the bid.

### C. PRE-BID MODIFICATION OR WITHDRAWAL OF OFFERS

Bids may be modified or withdrawn by written notice received at the Issuing Office before the bid opening date and time.

### D. CANCELLATION OF SOLICITATION/REJECTION OF ALL BIDS

The University reserves the right to cancel this IFB, to accept or reject any or all bids, in whole or in part, received in response to this IFB, and to waive or permit cure of minor irregularities as its best interests may require.

### E. INCURRED EXPENSES

The University assumes no responsibility for expenses incurred in preparing and submitting bids in response to this solicitation.

### F. ARREARAGES

By submitting a response to this solicitation, a bidder represents that it is not in arrears in the payment of any obligation due and owing the State of Maryland, including the payment of taxes and employee benefits, and that it shall not become so in arrears during the term of the contract if selected for contract award.

### G. VERIFICATION OF REGISTRATION AND TAX PAYMENT

Each prospective bidder is encouraged to ensure that it is appropriately registered to do business in the State of Maryland, and in good standing with respect to taxes, personal property returns, unemployment insurance, etc., before the bid opening date. Failure to complete registration with the State Department of Assessments and Taxation (SDAT) may disqualify an otherwise successful bidder from recommendation for contract award.

### H. ECONOMY OF PREPARATION

Bids should be prepared simply and economically, providing a straight-forward, concise description of the bidder's ability to fulfill the requirements of this solicitation.

### I. PUBLIC INFORMATION ACT NOTICE

Bidder shall give specific attention to identification of those portions of its bid considered confidential, or containing proprietary information or trade secrets. Upon request, bidder shall provide justification why such material should not be disclosed by the University under the Public Information Act, General Provisions Article, §§ 4-401 *et seq.*, Annotated Code of Maryland.

### J. EXECUTION OF BIDS

Bids shall be typewritten or written legibly in ink, and signed in ink as follows, depending on the bidder's form of business organization:

1. Sole Proprietorship. Proprietor shall sign full name, with address.

2. Partnership and Joint Venture. Submit the bid/price proposal form in the name of the partnership or joint venture. Clearly state the partnership name and the identity of each general partner, and execute all affidavits and certificates on behalf of the partnership, or on behalf of each general partner. No provision of any agreement among partners will be binding on the University unless it is disclosed in the Bidder's proposal. Reasonable evidence satisfactory to the University of the authority of one partner to bind other purported partners is required. Include a copy of the partnership agreement, if one exists. If no partnership agreement exists, and if the number of general partners is reasonably small, each general partner should execute all required documents. At the University's option, all general partners may be required to sign. Failure to present the University with satisfactory information concerning a purported partnership or joint venture may be grounds for bid rejection.
3. Corporation. An officer or authorized agent of the corporation shall sign with full name, indicate title, and include the name and address of the corporation. In the case of an authorized agent, enclose a letter from an officer of the corporation authorizing said individual to act on behalf of the corporation.

**K. DISCREPANCIES, EXPLANATIONS AND CLARIFICATIONS**

Bidders finding discrepancies in the specifications or other provisions included in this solicitation, or in doubt as to the meaning or intent of any section or subsection herein, shall request clarification from the Procurement Officer. Failure to request clarification prior to the due date shall be a waiver of any claim by the Bidder for expenses made necessary by reason of later interpretation of the contract documents, and Bidder shall be bound to the University's interpretation. Request clarifications in accordance with the instructions above.

**L. ORDER OF PRECEDENCE**

The contract to be entered into as a result of the IFB (the "Contract") will consist of the following contract documents listed in their order of precedence:

1. The contract executed by the parties and/or Purchase Order issued by the University;
2. The solicitation, including Exhibit A -2 Required Contract Provisions, and all other Exhibits; and
3. The bid as submitted by bidder and accepted by the University.

No modifications to this order of precedence will be accepted.

**M. REQUIRED CONTRACT PROVISIONS**

Bids submitted, and contract(s) executed with the successful bidder, are subject to Exhibit A and Exhibit A-2.

By submitting a bid, the vendor is deemed to have accepted the terms of this IFB, including exhibits; a bid that takes exception to the terms of the IFB may be rejected. Mutually agreeable modifications of the solicitation provisions, if allowed by law, will be documented by express identification in the final contract as superseding the pertinent provisions of the solicitation.

**N. FALSE STATEMENTS**

Bidders are advised that the Annotated Code of Maryland provides that in connection with a procurement contract, a person may not willfully: Falsify, conceal or suppress a material fact by any scheme or device; make a false or fraudulent statement or representation of a material fact; use a false writing or document that contains a false or fraudulent statement or entry of a material fact; or aid or conspire with another person to commit any of the aforementioned acts. A person who violates these provisions is guilty of a felony, and on conviction is subject to a fine not exceeding \$20,000 or imprisonment not exceeding five (5) years, or both.

**O. PAYMENT TO THE CONTRACTOR**

Payment is governed by Title 15, Subtitle 1, of the State Finance and Procurement Article, Annotated Code of Maryland. The State of Maryland is exempt from Maryland Retail Sales tax and Federal Excise Tax.

If the contract is a maintenance service/service contract, at the end of each calendar month, the Contractor shall render to the Accounts Payable Office, its invoice to [StratusAPinvoices@towson.edu](mailto:StratusAPinvoices@towson.edu) for services rendered the previous month. The amount shall not exceed one-twelfth (1/12) of the yearly service contract, unless otherwise specified in the Detailed Specifications.

**P. VENDOR ELECTRONIC FUNDS TRANSFER REGISTRATION**

Contractors of the State are required to complete a COT/GAD Form X-10, *Vendor Electronic Funds Transfer (EFT) Registration Request Form*, for each new contract with a value greater than \$200,000. Vendors must register for EFT by submitting a completed COT/GAD Form X-10 to the Comptroller's General Accounting Division (GAD) or request an exemption from GAD. The revised form is on the Comptroller's Web site at

[http://comptroller.marylandtaxes.com/Vendor\\_Services/Accounting\\_Information/Electronic\\_Funds\\_Transfer/](http://comptroller.marylandtaxes.com/Vendor_Services/Accounting_Information/Electronic_Funds_Transfer/)

**Q. RECIPROCAL PREFERENCE**

While Maryland law does not authorize state agencies to favor resident bidders, other states grant preferences to their residents over Maryland businesses. Therefore, a resident business preference may be given to a Maryland firm if: A responsible bidder whose headquarters, principal base of operations, or principal site that will provide the services required by this IFB is located in another state submits the most advantageous offer; the other state gives a preference to its residents through law, policy, or practice; and the preference does not conflict with a Federal law or grant affecting the contract. The preference given shall be identical to the preference that the other state gives to its residents.

**R. NON-VISUAL ACCESS**

The Contractor shall ensure compliance in any applicable contract with State of Maryland IT Non-Visual Access Standards. The standards should be incorporated to the fullest extent possible for information technology contracts. These standards/ policies may be revised from time to time and the Contractor shall comply with all such revisions. The Non-visual Access Clause noted in COMAR 21.05.08.05 and referenced in the IFB is the basis for the standards that have been incorporated in the Maryland regulations.

**S. INTERGOVERNMENTAL COOPERATIVE PURCHASING**

The University reserves the right to extend the terms, conditions, and prices of the contract awarded pursuant to this solicitation to other institutions of the University System of Maryland, and to other state educational institutions (e.g., St. Mary's College, Morgan State University, and Baltimore City Community College) and public agencies with similar requirements. Each such entity will issue its own purchasing documents; Towson University assumes no contractual obligations on behalf of other users of its contracts.

**T. PARKING**

All vehicles parked on Towson University property must strictly observe University parking regulations. Each vehicle parked on campus between 6 am and 8 pm, Monday through Thursday, and from 6 am to 3 pm on Fridays, must display a valid University permit unless parked at a paid meter. Parking on sidewalks or unpaved areas is prohibited at all times. All fines for parking or other vehicle violations are the responsibility of the Contractor. This applies to vendors, salespersons, company vehicles, and Contractor employees' personal vehicles. Long- and short-term permits are available, at designated rates, for vendors with contracts that require them to park regularly on the campus; see the parking website at <http://www.towson.edu/parking/visitors/index.html> for permit rates and information to support preparation of Bid/Price Proposal. Parking Transportation phone: (410) 704-7275. **NOTE: Include parking fees in Bid-/Price Proposal.**

**U. SMOKING**

Smoking, defined as the burning of tobacco or any other material in any type of smoking equipment, including but not restricted to cigarettes, cigars or pipes, is prohibited on all property owned, leased or operated by the University. This consists of all buildings, including residence halls, leased restaurants and lodging facilities; all grounds, including exterior open spaces, parking lots and garages, on-campus sidewalks, streets, driveways, stadiums, recreational spaces and practice facilities; and in all University-owned or leased vehicles. The policy applies to all individuals on the University campus, including faculty, staff, students, parents, vendors and visitors. Contractor and its employees and subcontractors who violate the policy may be denied access to the University campus.

**V. POLLINATOR PROTECTION ACT OF 2016 ([§5-2A-01](#))**

The sale and use of neonicotinoid pesticides is prohibited in the State, with certain exceptions

**W. ENVIRONMENTALLY PREFERABLE PURCHASING**

The State of Maryland is committed to purchasing environmentally preferable products and services (EPPs). Maryland's State Finance & Procurement Article §14-410 defines environmentally preferable purchasing as "the procurement or acquisition of goods and services that have a lesser or reduced effect on human health and the environment when compared with competing goods or services that serve the same purpose."

Accordingly, Bidders/Offerors are strongly encouraged to offer EPPs to fulfill this contract, to the greatest extent practicable.

**X. MARYLAND'S GREEN PURCHASING REPORTING REQUIREMENTS**

The State of Maryland requires, at a minimum, from the Contractor annual sales data over the life of this contract; the State also reserves the right to request quarterly sales data over the life of this contract.

The report shall include at a minimum details about the third-party sustainability certifications and other environmental attributes of products and services sold on this price agreement per the contract specifications.

To facilitate consistent reporting on this contract, the Contractor will be provided with a VENDOR GREEN SALES REPORT template from the Green Purchasing Committee (GPC), the Office of State Procurement (OSP) or the Department of General Services (DGS).

**Y. ENVIRONMENTAL CLAIMS**

All environmental benefit claims made by the Contractor concerning products or services offered on this contract must be consistent with the [Federal Trade Commission's Guidelines for the Use of Environmental Marketing Claims](#).

**END OF SECTION II.**

## SECTION III. BID SUBMISSION REQUIREMENTS

### A. ORGANIZATION OF BIDS

1. Bids must be submitted electronically not later than the date and time indicated on the Key Information Summary Sheet.
2. Submit via e-mail as an **attachment**. The e-mail address in which to submit the bid is [bids@towson.edu](mailto:bids@towson.edu). This e-mail address is for the receipt and storage of authorized Bids **ONLY**. It is not monitored for any other type of correspondence. All other correspondence should be directed to the appropriate procurement representative per the instructions contained in this document. The **project name and number must appear in subject line of email** along with your **company name**.
3. Any email attachment, or cumulative email attachments, at or exceeding 150MB in size will not be accepted by the University email system. Bidders are permitted to separate email attachments into multiple, clearly labeled, emails.
4. If technical data, product literature, or brochures are needed to supplement the bid, enclose those materials after the last required form.
5. Bids that are incomplete or that deviate from the format required in this section may be rejected.

### B. SUBMITTAL REQUIREMENTS CHECKLIST

Each bid must include the following:

1. **BID/PRICE PROPOSAL FORM**, typewritten or completed in ink and executed in accordance with the requirements in Section II. Each alteration to the Bid Form must be initialed, in ink, by the signatory.
2. **BID WORKSHEET (Excel)**
3. **Exhibit B, BID/PROPOSAL AFFIDAVIT**, typewritten or completed in ink and executed in accordance with the requirements in Section II.
4. **Exhibit F, COMPANY PROFILE**
5. **Exhibit G, FIRM EXPERIENCE**, duplicate as necessary to furnish references for no less than three (3) comparable projects completed within the past five (5) years, or currently underway.
6. **Exhibit H, BID BOND (if applicable)**
7. **Exhibit K, ADDENDA ACKNOWLEDGMENT FORM**. Should one or more addenda be issued, each bidder must acknowledge receipt using this form, identifying each addendum by number and date, and signing the document.
8. **Exhibit L, KEY PERSONNEL FORM**. Provide the names of key personnel and complete Exhibit L for each Key Personnel identified in Section IV.D.b (Contractor Supervisor, Site Supervisor-Moving, Site Supervisor- Turf Maintenance, Foreman- Mowing and Foreman- Turf Maintenance) as well as a brief resume on each, including educational background, work experience with bidder, previous work experience with other firms, and specific experience similar to the current project.

9. **ATTACHMENT A – VEHICLE & EQUIPMENT LIST**
10. **CERTIFICATES.** Please provide current copies of the following certificates with Bid submission:
- a. **Company**
    - i. Maryland Department of Agriculture Pesticide Applicators Certificate
    - ii. Fertilizer Applicator Business License
      - 1. Maryland’s Lawn Fertilizer Law requires lawn care professionals to be licensed and certified by the Maryland Department of Agriculture to apply fertilizer to the properties they manage.
    - iii. Commercial Pest Control License
      - 1. A pesticide business license, a firm must complete an application obtained from MDA, designate at least one person certified as a pest control applicator in the categories in which they are providing pest control services.
  - b. **Contract Supervisor**
    - i. MDE Responsible Person certificate

**C. CONTRACT AFFIDAVIT**

The Contract Affidavit included in this solicitation as Exhibit C is a sample, for information purposes only. If a contract is awarded as a result of this procurement, only the successful bidder must complete the Contract Affidavit.

**D. EVIDENCE OF BIDDER RESPONSIBILITY**

The University may require any bidder to furnish additional information regarding past performance, financial capacity, technical expertise, or other qualifications bearing on performance of the contract, and reserves the right to consider any information otherwise available, or to make such additional investigations as it deems necessary to confirm the responsibility of any bidder.

The Procurement Officer shall make purchases from, and award contracts, only to responsible contractors. In the absence of information clearly indicating that the prospective contractor is responsible, the Procurement Officer shall make a determination of non-responsibility.

**END OF SECTION III.**

## SECTION IV. SPECIFICATIONS

### A. SCOPE

Towson University is seeking an experienced, certified small business contractor to provide comprehensive landscape site maintenance for Towson University Northeast Campus, Harford County (T.U.N.E.). The successful Contractor shall provide all necessary labor, supervision, tools, equipment, and material necessary to provide a groomed and welcoming appearance of the property. Services shall include, but not be limited to:

1. Mowing and trimming, including trash and debris removal, edging, blowing.
2. Application of pesticides and fertilizers. Applications shall include Contractor supplied products.
3. Mulching – trees and beds
4. Tree pruning to 20 feet ht.
5. Planter color rotation
6. Meadow management - Mowing, Invasive woody plant removal
7. Parking lot and street sweeping as needed.

All work shall be completed in a manner satisfactory to the TU Landscape Services Manager.

### B. CONTRACT PERIOD

The base one-year contract period shall begin on or about January 1, 2024, to December 31, 2024, with the University reserving the right to exercise, at its sole option, four (4) one-year renewal options.

### C. CONTRACT PRICING

- a. Contractors shall provide pricing for mowing and trimming, including trash and debris removal, edging, blowing, application of pesticides and fertilizers, applications shall, mulching – trees and beds, tree trimming, planter color rotation meadow management, invasive woody plant removal, parking lot and street sweeping as needed and ad hoc services.
- b. “Flat rates” are to be inclusive of all, equipment and labor for each designated service as indicated on the Bid Worksheet.
- c. TU is also requesting additional services which may be utilized on an ad hoc basis. Those services shall be bid using a fully loaded hourly rate, or a flat rate as indicated on the Bid Worksheet.
- d. Prices for the four (4) one-year renewal option years may be adjusted (up or down) in accordance with the Consumer Price Index, All Urban Consumers (CPI-U), US City Average, all items, as published by the Bureau of Labor Statistics, US Department of Commerce, for the most recent and available 12-month period at the time of renewal for the DC/MD Region. Any adjustment may not exceed 3%.



## **D. GENERAL INFORMATION AND REQUIREMENTS**

- a. Contractor Employees:
  - i. The Contractor shall always provide a full-time uniformed supervisor on campus while work is in progress.
  - ii. Contractor employees assigned to a specific work area shall remain in the area unless instructed by the supervisor for whom they are working to move to another assignment.
  - iii. Only necessary work clothing and outer gear shall be brought to the campus. Personal clothing attire or belongings that are not in keeping with the University's policies shall not be allowed. Personal items approved to be on the campus shall be clearly identified as belonging to the employee prior to being brought onto campus.
  - iv. All Contractor personnel shall be dressed in uniforms displaying the company name and identification badge.
  - v. Contractor Supervisor is required to be certified as MDE Responsible Person and crew members required to have annual Storm Water Management training. The University will provide a link for required training. Certificates of completion shall be electronically delivered to Landscape Manager annually at the beginning of each contract year.
  - vi. Contractor employees shall be required to conduct themselves in a manner not to disrupt any University activity. Any loud, abusive, or profound language shall be unacceptable.
  
- b. Contractor Key Personnel
  - i. Contractor Supervisor (Company Officer, Owner, Branch Manager)
    - 1. Responsible for overall day to day functioning of the company
    - 2. Required to be certified as MDE Responsible Person
  - ii. Site Supervisor – Mowing (Operations Supervisor, Project Managers)
    - 1. Responsible directly for specific site project or operations
  - iii. Site Supervisor – Turf Maintenance (Operations Supervisor, Project Manager)
    - 1. Responsible directly for specific site project or operations
  - iv. Site Supervisor – Stormwater (Operations Supervisor, Project Manager)
    - 1. Responsible directly for specific site project or operations
  - v. Foreman – Turf Maintenance
    - 1. Responsible for directing crew while on the worksite.
  - vii. Foreman – Stormwater BMP maintenance
    - 1. Directed crew while on the worksite.
  - iv. Pesticide Applicator – licensed
    - 1. Responsible for supervising registered personnel or applying pesticides.
  
- c. Subcontractors: Subcontractors shall not be permitted without the approval of the University. The allowable subcontractor markup shall not exceed 10%.

- d. **Personnel Removal:** With due justification, the University reserves the right to instruct the Contractor to remove and replace any of its employees. If such removal is instructed by the University, employee must be removed immediately and replaced within 24 hours, unless another time frame is agreed to by the University.
- e. **Contractor Access:** Access routes, entrance gates, parking, and storage areas, etc., shall be as directed by the Towson University North Campus Operations Manager (TU Operations Manager"). The Contractor shall conduct all operations in strict observation of the access routes and other areas established as described above. Observance shall include any imposed time limitations.
- f. **Response Time:** The Contractor must be aware that there will be occasions whereby response time is of the utmost importance. The Contractor must have the ability to perform some jobs within very tight time frames. In these cases, the Contractor shall be required to respond and complete tasks within four (4) hours.
- g. **Spills:** Any illicit spills shall be immediately reported to the TU Operations Manager **410-704-8022**. Towson University Work Control ("Work Control") **410-704-2481** is also immediately notified. Any physical damage, i.e., broken windows, turf, or plant damage, caused by The Contractor, shall make a report to the TU Operations Manager **410-704-8022**. Any costs associated with negligence by The Contractor will be paid as determined by the Towson University Insurance Administrator.
- h. **List of Employees:** The Contractor shall provide to the TU Operations Manager or designee a list of all persons who will be performing work. The list shall include regular employees, back-up employees, part-time employees and supervisors and be always kept up to date. The Contractor shall provide notice to the TU Operations Manager within twenty-four (24) hours of the dismissal of any employee.
- i. **Employee Safety:** The Contractor shall be responsible for the safety of their employees in compliance with all Federal and State regulations.
- j. **Work Initiation Conference:** A work initiation conference shall be held prior to the start of the contract. The Contractor shall have proper representation at the meeting. Areas discussed during the meeting include:
- Contractual requirements.
  - Projected schedules; and
  - Administrative procedures
  - Area Locations
  - Chemicals/MSDS's
- k. **Reports to the University:** **The Contractor shall provide written service tickets, detailing work completed each visit, to the University, which will be submitted to the TU Operations Manager designated location after each visit.** The Contractor shall promptly report in email to the TU Operations Manager any existing conditions and/or circumstances resulting from acts of the University or University personnel which interfere with the performance of work in accordance with the specifications. Upon receipt of such report from the Contractor, TU Operations Manager shall take immediate steps to have such conditions and/or circumstances investigated and corrected.

- l. Cellular/Mobile Phone Service: The on-site supervisor shall always possess and utilize a cell phone while contractual work is performed on campus. The cell phone number shall be provided to the TU Operations Manager. The Contractor shall also provide the on-site Supervisor's off-site Manager's mobile phone number. Expenses for the phone shall be borne by the Contractor.
- m. Invoices: All invoices shall be submitted the [StratUsAPinvoices@towson.edu](mailto:StratUsAPinvoices@towson.edu) for payment. Invoices containing charges for services not provided, not completed, or incorrect charges will not be paid. All invoices shall include the following:
  - Purchase Order Number – **Note: without purchase order number, the invoice payment will be delayed.**
  - Date work was started and completed.
  - Service ticket, noting area & acres completed.
  - TU Operations Manager Approval Signature
  - Contractor Federal Tax ID number
  - Charges consistent with contract rates
  - **Failure to adhere to these invoicing procedures will result in delay of payment.**
- k. Regular Work Hours: Weekday work hours will be 7:00 am – 5:00 pm and weekend work hours will be 9:00 am – 5:00 pm.
- l. Off Hours Work "Off Hours Work" is work that is performed outside of regular working hours as described in Scope of Work Section D.k. Towson University shall not be responsible for off hours work charges, unless the Landscape Services Manager has provided prior approval. Off Hours Work shall be billed at 1.5 times the regular hourly rates that are provided on the Bid Worksheet.
- m. Materials: The markup on Contractor provided hardgoods materials shall be capped at 10%. Living plant material markup shall be capped at 15% with one year warranty from acceptance.
- n. Security: The Contractor shall be fully responsible for maintaining the security of the University as it relates to Contractor employees. It is the sole responsibility of the Contractor to become familiar with and abide by the rules and regulations governing security at the University. Regulations are available from the University Police. Under no circumstances is a contractor employee allowed in any resident facility.

## **E. GRASS MOWING, TRIMMING**

- a. Definitions:
  - i. Grass - all cultivated and uncultivated, growing, or dormant, grasses, weeds, and vegetation existing or subsequently in lawn and median areas.
  - ii. Mowing - the cutting of grass by manual or mechanical means to a uniform finished height free of ridges, ragged edges, or scalping.
  - iii. Trimming - the cutting of grass by manual or mechanical means to complete mowing of a specified area where it is impractical to mow the entire area with one piece of equipment. Examples are areas that contain buildings, flowerbeds, bushes, trees, shrubs, power poles, pipes, valves, signs, guy wires, slopes, drainage ditches or any other stationary obstruction encountered.
  - iv. Grass Clippings - that portion of grass that is no longer attached to the grass plant and remains on or in the grass plant or remains on or in the grass after mowing or trimming.

- v. Sweeping/Blowing - the picking up and removal of, by manual or mechanical means, all grass clippings from mowing or trimming.
  - vi. Edging - the removal of, by manual or mechanical means, grass, sod, dirt, or other material which has grown onto or covers the edges, joints or cracks of sidewalks, curbs, or other improvements.
  - vii. Meadow – refers to a plant community made up of native grasses, sedges, and forbs, grown from seed.
  - viii. Woody Invaded Meadow - woody-invaded meadow as having a canopy cover of more than 10% trees and shrub thickets, and an understory dominated by native species (>75% cover)
- b. Grass Mowing Operating Specifications: SEE EXHIBIT M-Mowing Exhibit
- i. Trash and debris shall be picked up and removed prior to mowing. Only insignificant amounts of trash and debris shall be deposited in trashcans or dumpsters located at various points throughout campus.
  - ii. All areas except the meadow shall be mowed and trimmed to a uniform height every five (7) to seven (10) days, Calculated from the first day of the previous 3 days of consecutive mowing, at a height of three (3) to four (4) inches, free of ridges, ragged edges, or scalping. This includes median strips and guardrails. Grass shall be mowed and trimmed as frequently as necessary to maintain the desired height, not to exceed 4.5" in height and as determined by the Landscape Services Manager. **Note:** The meadow shall be mowed once a year in late Fall.
  - iii. Guardrails shall be trimmed and mowed one mower width behind the guard rail when possible.
  - iv. Trimming shall be performed immediately preceding or following mowing. In each individual area, sweeping or blowing of sidewalks shall be performed immediately following completion of mowing and trimming.
  - v. **NOTE: Each individual area shall be mowed, trimmed and sidewalks cleaned before proceeding to the next area.**
  - vi. Sweeping and/or blowing of clippings shall be done so that no clippings remain on areas other than grass. Under no circumstances are clippings to be blown onto concrete/asphalt areas, on any parked vehicles or up against buildings, windows, vents, mulched shrub beds and mulched tree rings, in storm drains, etc., in the area.
  - vii. Movable obstructions shall be moved, the area trimmed and mowed, and then returned to the original location (i.e., trashcans, picnic tables, lawn ornaments, etc. Any physical damage to the moveable obstructions, caused by The Contractor, needs to be reported to Work Control, **410-704-2481**, and the TU Operations Manager. Any costs associated with negligence by The Contractor will be paid as determined by the Towson University Insurance Administrator.
  - viii. Edging of curbs and sidewalks shall be performed during each cutting. Mechanical edging with steel blade or edging disk of sidewalks shall be performed two times per month. Material shall be completely removed from all joints and cracks and removed to one (1") inch beyond and below the edge of the sidewalk, or curb. Edging on a 90-degree angle shall be uniform to create a neat and clean appearance. All edging waste shall be properly disposed of.
  - ix. The Contractor shall be responsible for mowing/weed removal on banks/sloped areas per frequency on pricing sheet.
    - x. The Contractor shall make every effort to maintain a normal flow of pedestrian traffic and to protect the public from any hazards associated with lawn mowing operations.
    - xi. All work shall be performed in a professional, safe, and courteous manner.
    - xii. Onsite fueling of equipment will be done according to industry standards to prevent damage to any asphalted, concreted, or landscaped areas.

c. Work Hours and Schedules

- i. Work shall not begin before 7:00 am on weekdays and weekends. Upon commencement of operations. Contractor shall provide the appropriate number of crew members to be capable of mowing and trimming the entire campus within three (3) consecutive days, weather permitting.
- ii. Mowing operations shall be performed between dawn and dusk, Monday through Saturday, including holidays. Sundays may be used for make-up days due to inclement weather, but the Contractor must receive the approval of the TU Operations Manager prior to appearing on campus.
- iii. The University reserves the right to cancel any mowing operations that may interfere with campus activities and events.
- iv. Mowing shall not be permitted around any building when classes or other scheduled activities are in session without prior approval by the University's Operations Manager.
- v. **The Contractor shall contact the TU Operations Manager no fewer than twenty-four (24) hours prior to commencement of any mowing operations on campus unless prior arrangements were mutually agreed upon. The schedule presented by the Contractor is subject to change at any time by the TU Operations Manager.**

**\*\*\*NOTE: The Contractor shall contact the TU Operations Manager upon the start of each workday. The Contractor must be flexible to accommodate the University scheduled events that change frequently.**

d. Equipment Requirements:

- i. All equipment shall be acceptable for commercial mowing and of the type and design best suited for the operation being performed.
- ii. All Contractor equipment shall be equipped with the proper safety devices, as prescribed by the original manufacturer, and such equipment shall satisfy all applicable OSHA regulations.
- iii. The Contractor shall furnish and maintain all required equipment in good, safe operating condition.
- iv. Equipment shall be subject to inspection by the TU Operations Manager at any time during the performance of the contract. Any equipment found to be in poor mechanical or unsafe condition shall be immediately removed from operation and repaired prior to return to service. The TU Operations Manager may direct that any equipment deemed not repairable be permanently removed from the job site. The TU Operations Manager may direct that any equipment deemed unsuitable because it is not the proper type to perform the operation be permanently removed from the job site.
- v. All mowing equipment shall be equipped with adjustable cutting heights.
- vi. Cutting blades shall be kept sharp to cut grass cleanly and efficiently.
- vii. All riding lawnmowers shall be equipped with slow moving vehicle signs and operated at a safe speed.
- viii. Operators of equipment shall be trained and capable personnel to ensure no damage to the turf, trees, other obstructions, abuse of equipment or cut debris that increases littering.
- ix. The Contractor shall provide standby equipment and supplies if necessary to maintain the mowing schedule.
- x. All fuel containers shall be always secured. Containers shall not be unattended while performing work on campus. Fuel containers will be a Type I Safety Can, with spring closing lid, non-sparking flame arrestor, and spout.

## **F. MULCHING AND BED PREPARATION SPECIFICATIONS**

Hardwood double shredded mulch will be provided by The University unless mutually agreed upon by the Landscape Services Manager and the Contractor.

- i. Contractor shall use approved natural color hardwood double shredded mulch for all applications.
- ii. Provide all labor, tools, equipment and materials for bed preparation and mulching, including edging of beds, and light cleanup.
- iii. Edge previously mulched beds to create a 90-degree edge with a depth of 3" and remove resulting debris from site. Single tree plantings in turf shall have the trunk of the tree located in the center of the mulched area (tree ring). Edging shall be performed with a walk behind bed edger. Gas powered handheld bed re-definer shall not be utilized.
- iv. **Remove all existing mulch and/or excess soil** to expose the root flare and so that when new mulch is applied, there is no more than a total 2" of mulch. Dispose of old mulch and or soil legally and sustainably off-campus.
- v. Remove debris and trash from tree rings beds.
- vi. Thoroughly weed area by manually removing all weeds. Upon prior approval of Landscape Manager, chemically treating all weeds or a combination of both.
- vii. Apply pre-emergent to tree rings and beds approved equal before installing mulch.
- viii. Use hardwood double shredded natural color mulch to the depth of two (2") inches deep in accordance with current horticultural standards.
- ix. Contractor shall be responsible for cleaning of hard surfaces, lawn, and flowers where mulch is applied. Contractor shall be responsible for containment of mulch within shrub beds, all areas surrounding planting/flower beds. All areas shall be back to original clean condition.
- x. Application shall be coordinated with the Operations Manager.

## **G. TREE MAINTENANCE : EXHIBIT O-Planting Plan**

- a. Trim all trees that within 20 feet in height and 10 inches diameter at the base, once a year at appropriate time of year for each species, as necessary.
- b. Remove all dead, diseased, and unsightly branches, and dead trees. Prune for natural shape. Trees are to be trimmed to maintain adequate clearance for pedestrians on sidewalks at the height of 8 feet. Fertilize in the fall as needed.
- c. Mulching - Remove old mulch before applying new mulch edge tree ring. Enlarge tree rings as necessary to accommodate mowing safely.
- d. All structural weaknesses such as split crotch or limbs, diseased or decayed limbs, or other severe damage shall be immediately reported to TU Operations Manager.
- e. The Contractor shall remove trimmings and all cuttings and debris from the site.
- f. Tree rings are to be kept weed free through the growing season. If utilizing chemical weed preventative products, apply according to the label.
- g. Treat according to IPM practices any pests according to Maryland State Pesticide laws. Submit pesticide labels and submit treatment report to TU Operation Manager by email. Pesticide report should include product label, amount of product used date and time of day.

## **H. ENTRANCE PLANTER MAINTENANCE**

- a. Provide spring mixed annual color for each of two entrance planters by May 15.
- b. Provide evergreen plant for each of two entrance planters by November 1.
- c. Add or remove soil as needed and apply initial watering.

## **I. THE MEADOW MANAGEMENT : EXHIBIT N-Planning Details & Notes**

- a. The meadow shall be mowed once a year February -March.
- b. Meadow Maintenance of woody plants
  - i. Spot Treatments -Woody and invasive plants shall be spot treated, as necessary.
  - ii. Removals - If trees and woody shrubs increase, selective removal is required to maintain the meadow's function and aesthetic. Most woody seedlings may be cut down during mowing or spot treatments. Large woody plants shall be removed mechanically, or a combination of mechanical and chemical treatment approved by the Landscape Services Manager.
  - iii. Reseeding - Bare soil spots from removed plants shall be seeded with appropriate seed mix approved by Landscape Services Manager

## **J. LAWN TURF PESTICIDE AND FERTILIZER APPLICATIONS – ADDITIONAL SERVICES**

- a. The Contractor will provide all equipment and labor to apply turf chemicals and fertilizers and invasive weed treatments according to the stormwater permit requirements on an as needed basis. Chemicals and fertilizers will be provided by the Contractor. Equipment must be appropriate for both turf applications and invasive weed control. Products should be appropriate for the University grounds and campus community keeping in mind campus sensitivity.
- b. NOTE: Contractor is responsible for soil testing of representative campus sites before initial fertilizer treatments and every three years thereafter according to Maryland's Lawn Fertilizer Law. The Contractor will also provide testing reports to the University.
- c. Chemical applications are to be scheduled based on mutually agreed upon times between the Operation Manager and the Contractor. Weekend days are preferred for applications during the University academic calendar. (August through Memorial Day)
- d. All materials are to be used in accordance with applicable laws and products' labeled instructions. All applications are to be coordinated with TU Operations Manager. Proper signage shall be installed after all chemical applications. Proper Personal Protective Equipment (PPE) is necessary always must be provided by contractor.
- e. Contractor must have a current "Maryland Department of Agriculture Pesticide Applicator's Certificate" and Professional Fertilizer Applicator (pfa) Certification. Chemical and/or fertilizer labels shall be always on-site during applications.
- f. For each application shall be report shall be emailed at the time of the corresponding invoice.

## **K. PARKING LOT AND STREET SWEEPING – ADDITIONAL SERVICE**

- g. Contractor must have a current “Maryland Department of Agriculture Pesticide Applicator’s Certificate” and Professional Fertilizer Applicator (pfa) Certification. Chemical and/or fertilizer labels shall be always on-site during applications.
- h. Provide sweeping, vacuuming, and hand cleaning services for campus parking lot and streets on an as needed basis.
- i. Quality of Services - Contractor shall remove all debris from all parking lots and streets every sweeping cycle. The Contractor shall make as many passes as necessary to accomplish the task. This action will include removal such as sand, glass, paper, cans, rocks, shredded tires, leaves, and other materials. The University reserves the right to require that streets be re-swept by Contractor without charge, if inspection by the Operations Manager reveals that the parking lots and streets were not swept to the University’s standard. The Contractor shall, if directed by the Operations Manager, re-sweep the area in question within 24 hours of receipt of verbal or written notification.
- j. Sweeper Speeds - Street sweeper shall be operated at speeds that are appropriate for traffic conditions and as recommended by the equipment manufacturer for optimal performance.
- k. Water Usage - water meter must be utilized for any campus hydrant water usage. Note: The measurement should be reported on the invoice.
- l. Disposal of Sweep waste - Contractor will be responsible for all materials swept and shall properly dispose of materials collected. The Contractor is required to report weight all debris collected for each service visit.
- m. Mileage Calculations - Compensation for miles of sweeping shall be calculated according to actual curb miles swept. The Contractor shall supply individual mileage logs with each invoice. Areas that are re-swept to meet the University satisfaction level should not be included in the mileage log.
- n. Hours of Operation - Service will be scheduled at a pre-determined time by the Operations Manager. The Contractor schedule will be based on university class and event schedules.
- o. Weather - For this contract, Weather Works shall be the weather forecasting and reporting agency. No cleaning operations shall be conducted when there are climatic conditions present or forecast that would make such an operation ineffectual or dangerous.
- p. Equipment - The Contractor shall provide equipment in good working condition, labor, fuel, and any other materials necessary to complete the required work. The equipment used for cleaning



shall be sufficient type, capacity, and quantity to safely and efficiently perform the cleaning work as specified.

**END OF SECTION IV.**

**The Contractor must contact the TU's Department of Environmental Health and Safety (EHS) (410-704-2949) immediately following any spill of a hazardous material in excess of one (1) quart.**

**1. Occupational Safety And Health Act (O.S.H.A.)**

All materials, supplies, equipment, or services supplied as a result of this Contract shall comply with the applicable US and Maryland Occupational Safety and Health Act standards.

**2. Hazard Communication Standard**

The Contractor will be responsible for advising all of its employees of their rights under the University's Hazard Communication Program, or more commonly referred to as the Right To Know (RTK) Program. The University will supply the vendor with sufficient copies of its Employee Safety Program (ESP) booklet which outlines this program. Each and every Contractor who physically works on campus shall be required to sign a form acknowledging the receipt of the ESP booklet and their rights/responsibilities pursuant to this program. The University's Department of Environmental Health and Safety is responsible for administering the RTK program and will handle all information regarding this program. Failure to adhere to the requirements of the RTK Program may result in implementation of punitive action such as the cancellation of the contract(s).

Pursuant to the provisions of the RTK Program, the Contractor will be responsible for the following:

**a.** Submission to the Contract Services Office and EHS of a complete list of all chemicals or chemical products to be used on the University's property. This listing shall include the chemical name, common name, manufacturer's name, quantity and location (building and room number) for each product. This listing shall be given to EHS by no later than two (2) weeks prior to the start of any work under this contract. Changes, additions, or deletions to the complete campus chemical list must be submitted in writing five (5) working days prior to the actual change occurring. All proposed changes must be approved in writing by EHS prior to the actual use of the new product on campus.

**b.** Submission to the Contract Services Office and EHS of the manufacturer's Material Safety Data Sheet (MSDS) for all chemicals or chemical products to be used or in use at the University. These MSDS must be delivered, no later than two (2) weeks prior to the start of any work under this contract. There must be a MSDS for every product in use or present on the campus unless exempted in writing by EHS. MSDS's for any changes or additions to the complete campus chemical list must be submitted five (5) working days prior to the actual change occurring. All proposed changes must be approved in writing by EHS prior to the actual use of the new product on campus. The University, through EHS, reserves the right to order a change in the use, storage, or method of handling of

any chemical/chemical product that it feels poses an unreasonable hazard to the University's community.

NOTE: In the absence of the original manufacturer's MSDS, EHS will accept a generic equivalent as long as a letter from the Contractor stating that the original is not available is attached.

**c.** The Contractor must warrant in writing to Towson University's Contract Administrator that all employees have been trained and will continue to be trained in the proper and safe storage, handling, use and disposal of all chemicals/chemical products in use.

**d.** The Contractor agrees to obey and follow all local, state, and federal regulations regarding the storage, handling, use and disposal of all chemicals/chemical products. The Contractor agrees to properly dispose of all regulated waste in accordance with all applicable regulations and to make available to EHS all records necessary to support such activity.

**3. Asbestos**

The Contractor is responsible for training and equipping all personnel concerning work in asbestos environments as applicable. They must be trained as prescribed by COMAR 26.11.21. All new employees must be trained within 30 days after they are hired by the Contractor. This is to be accomplished at no additional cost to this contract or the University. An initial report on all employees as to their asbestos training will be presented to the Contract Administrator within the first 90 days of the Contract and updated on a monthly basis. Thereafter, failure to comply with this requirement would place the Contractor in default status.

**4. Lead Paint**

The Contractor is responsible for training and equipping all personnel concerning work in lead paint containing environments as applicable. Employees must be trained as required within 60 days of contract commencement and all new employees must be trained within 30 days after they are hired by the Contractor. This training will be provided by the Contractor at no additional cost to this contract or the University. An initial report on all employees as to their lead paint training will be presented to the Contract Administrator within the first 90 days of the contract and updated on a monthly basis. Thereafter, failure to comply with this requirement would place the Contractor in default status.

**5. Fire Safety**

The Contractor agrees to comply with and follow all local, state, federal and University regulations regarding fire safety. It is the Contractor's sole responsibility to become familiar with all of the applicable regulations and policies. Copies of the University's policies and procedures are available from EHS.

The Contractor will be responsible for the following:

**a** To provide all of its employees with sufficient training to ensure that they are fully aware of all pertinent regulations and policies in effect regarding fire safety.

**b** To ensure that all of its employees are aware of and react to the University's Emergency Procedures including, but not limited to, fire drills and evacuations. All employees must be instructed on the proper personnel to call to report an emergency.

**c** All portable electrical devices including extension cords should be disconnected at the completion of the work assigned. All electrical equipment must be approved by Underwriters Laboratory and maintained in good working order. Under no circumstances shall damaged electrical equipment be utilized on this campus.

**d** After pulling the fire alarm, evacuate the building to a safe location and contact the University Police by dialing extension 42133 immediately. If using a pay phone, dial 911 direct.

**e** SMOKING IS NOT ALLOWED IN ANY OF THE BUILDINGS. Any employee of the Contractor, who wishes to smoke during a designated break, must do so outside.

The Contractor is responsible for fully complying with TU Hot Works Permitting Program. A Hot Works Permit is required any time a Contractor is doing any work on campus involving an actual or potential source of ignition (e.g., arc or gas welding, torch cutting, brazing, open flame soldering, grinding, fired space heaters, etc.); or may potentially cause the activation of a building fire alarm system; or may cause building occupants to notify emergency response agencies about the smell of smoke, heat, etc.

Hot Works Permits are issued prior to the start of the work by EHS at 410-704-2949.

The Contractor assumes all responsibility for any work delays associated with noncompliance with the Hot Works Permit Program.

## **6. Bloodborne Pathogens**

The Contractor will be responsible for providing the required training dealing with occupational exposure to bloodborne pathogens. Employees who have received this training may be required to perform services in areas where they may be at risk of exposure to blood or other potentially infectious materials. Some responsibilities will include collection of domestic trash in areas that generate special medical waste, regular cleaning in these areas and spill response for accidents that occur on campus that involve blood. Employees must be informed on the potential hazards present in these areas and the proper protective measures that can be taken to prevent exposure. EHS is available to provide more information concerning the areas on campus where personnel are at risk of exposure.

## **7. Confined Space Entry**

The Contractor agrees to comply with all local, state and federal regulations pertaining to the entry into confined spaces. The Contractor is responsible for contacting the TU's Contract Services Manager in the Department of Facilities Management for the location of all campus-confined spaces and for identifying any confined space hazards **prior** to entry into a confined space. The Contractor is responsible for ensuring his/her workers and Subcontractors are adequately trained in confined space entry procedures in accordance with OSHA 1910.146, Permit Required Confined Spaces for General Industry.

The Contractor will provide the Contract Administrator with a written copy of their Confined Space Entry Plan (CSEP) for review and approval at least 5 working days in advance of the planned entry. Prior to work commencements, the Contractor will also certify in writing that all of his/her workers and Subcontractors have been trained in accordance with OSHA 1910.146, Permit Required Confined Spaces for General Industry. This certification will list all employees working on campus by name and social security number.

If the Contractor's CSEP is approved, the Contractor may utilize his/her CSEP for entering into campus confined spaces. If disapproved, or if the Contractor does not have a written CSEP, the Contractor will comply with the University's CSEP. Until such time as the Contractor provides written certification that all of his/her employees and Subcontractor employees working on campus have been adequately trained in confined space entry procedures, entry in TU confined spaces is strictly forbidden. Questions concerning TU CSEP should be directed to EHS.

The Contractor assumes all responsibility for any work delays associated with noncompliance with confined space regulations.

## **8. Respiratory Protection**

The Contractor agrees to comply with all local, state and federal regulations pertaining to the use of respiratory protection equipment. It is the Contractor's responsibility to ensure their workers are provided and wearing the appropriate respiratory protection device suitable to the hazard.

The Contractor will provide the Contract Administrator with a written copy of their Respiratory Protection Plan (RPP) for review and approval at least 5 workdays in advance of the planned entry. If approved, the Contractor may utilize his/her RPP while on campus. If disapproved, or if the Contractor does not have a written RPP, the Contractor will comply with the University's RPP. Questions concerning TU RPP should be directed to EHS at 410-704-2949.

The Contractor assumes all responsibility for any work delays associated with noncompliance with respiratory protection regulations.

## 9. Waste Disposal

The Contractor is responsible for the removal and disposal of all non-hazardous waste products generated from his/her work on campus. All non-hazardous waste materials generated by the Contractor shall be removed from campus (unless otherwise specified) and disposed of in accordance with all applicable federal, state and county laws and regulations. The University reserves the right to require the use of a TU Non-Hazardous Waste Manifest for transport off campus of any University non-hazardous waste. The University also reserves the right to approve or disapprove the facility(ies) the Contractor utilizes for disposal of any University non-hazardous wastes (as necessary). All costs will be borne by the Contractor for the disposal of all hazardous or non-hazardous wastes, unless otherwise specified in the contract.

Under no circumstances is any Contractor's generated hazardous waste to be disposed of on campus. The Contractor is responsible for the removal and proper disposal of all his/her hazardous waste, in accordance with all applicable federal, state and county laws and regulations. Contractor's generated hazardous waste is waste resulting from their operations/equipment on campus when using Contractor owned/supplied materials/chemicals. Disposal costs for this will be borne solely by the Contractor.

The University routinely performs wastewater monitoring in accordance with its Industrial Wastewater Discharge Permit and routinely screens campus discharges for hazardous wastes. The Contractor will be held liable for any assessed penalties attributable to the improper discharge of hazardous wastes from campus facilities.

Contracts that require Contractors to transport and/or dispose of regulated hazardous materials (i.e., hazardous wastes) owned and/or generated by Towson University will be disposed of by Towson University Environmental Health & Safety utilizing existing University hazardous waste disposal contractors. The Contractor should contact EHS as soon as the hazardous wastes have been identified to coordinate the disposal.

All transportation and disposal costs will be paid by Towson University and then back charged to the Contractor.

Any questions concerning the disposal of hazardous or non-hazardous waste should be directed to EHS at 410-704-2949.

## 10. The Control of Hazardous Energy Source (Lock Out/Tag Out)

The Contractor agrees to comply with all local, state and federal regulations pertaining to the control of hazardous energy sources. The Contractor is responsible for insuring his/her workers and any Subcontractors are adequately trained in Lockout/Tagout procedures in accordance with OSHA 1910.147, The Control of Hazardous Energy Sources (Lock Out/Tag Out).

The Contractor will provide the Contract Administrator with a written copy of their Lock Out/Tag Out policy (LO/TO) and/or procedures for review and approval at least five (5) working days in advance of the commencement date of the contract.

Prior to work commencement, the Contractor will also certify in writing that all of his/her workers and Subcontractors have been trained in accordance with OSHA 1910.147. This certification will list all employees working on campus by name and social security number.

If the Contractor's LO/TO is approved, the Contractor may utilize their LO/TO for work on hazardous energy sources. If disapproved, or if the Contractor does not have a written LO/TO, the Contractor will comply with TU LO/TO Policy/Procedures. Until such time as the Contractor provides written certification that all his/her employees and Subcontractors working on campus have been adequately trained in LO/TO procedures, work on hazardous energy sources is strictly forbidden. Questions concerning TU LO/TO Policy/Procedures shall be directed to EHS at 410-704-2949.

The Contractor assumes all responsibility for any work delays associated with noncompliance with the control of Hazardous Energy Sources regulations.

## 11. Wastewater/Sewer Discharge

The University's Wastewater Discharge Permit strictly prohibits the disposal of waste chemicals and corrosives via the sanitary sewer system. NO waste chemicals (i.e., old, unused, excess, etc.), including, but not limited to, organic solvents and/or corrosives (pH less than or equal to 6 and greater than or equal to 10) will be disposed of on campus via the sanitary sewer system without advance written approval of the TU Department of Environmental Health & Safety (EHS). The Contractor shall submit MSDS's for all waste chemicals they wish to dispose of in the sanitary sewer to EHS five (5) working days in advance for approval.

The University routinely performs wastewater monitoring in accordance with its Industrial Wastewater Discharge Permit and routinely screens campus discharges for waste chemicals and corrosives. The Contractor will be held liable for any assessed penalties attributable to the improper discharge of these materials from campus facilities.

The Contractor is subject to unannounced inspections of the chemicals their employees are using on campus. TU Department of Environmental Health & Safety will conduct these unannounced inspections.

## 12. Safety Training/Inspections/Meetings

The Contractor is responsible to notify the Contract Administrator five (5) working days in advance of the date, time and location of their monthly safety meeting.

## 13. Materials

No asbestos, lead, or PCB containing materials (0%) are to be utilized /installed on campus unless prior written approval has been received from the University's Department of Environmental Health & Safety (410-704-2949).

## 14. Stormwater Pollution Prevention/Prohibition of Illicit Discharges

No person shall cause or contribute discharge directly or indirectly into the Towson University municipal storm drain system or waterways any materials, including but not limited to pollutants or waters containing any pollutants that cause or contribute to a violation of applicable water quality standards, other than storm water.

Refer to **06-20.00 – University Policy on Stormwater Illicit Discharge Detection and Elimination** for additional [information](#).

No person may improperly store, handle, use or apply any pollutant in a manner that will cause its exposure to rainfall, runoff and discharge into the Towson University municipal storm water drain system or campus waterways.

The commencement, conduct or continuance of any illegal discharge to the storm drain system is prohibited except as described:

**a.** The following discharges are exempt from discharge prohibitions:

water line flushing or other potable water sources, landscape irrigation or lawn watering, diverted stream flows, rising ground water, ground water infiltration to storm drains, uncontaminated pumped ground water, foundation or footing drains (not including active groundwater dewatering systems), crawl space pumps, air conditioning condensation, springs, non-commercial washing of vehicles, natural riparian habitat or wet-land flows, swimming pools (if dechlorinated - typically less than one PPM chlorine), fire-fighting activities, and any other water source not containing pollutants.

**b.** Any discharges specified in writing by Towson University Environmental Health & Safety as being necessary to protect public health and safety.

**c.** Dye testing only with required verbal notification to Towson University Environmental Health & Safety [(410) 704-2949 or [safety@towson.edu](mailto:safety@towson.edu)] prior to the time of the test.

**d.** The following discharges are exempt from discharge prohibitions: water line flushing or other potable water sources, landscape irrigation or lawn watering, diverted stream flows, rising ground water, ground water infiltration to storm drains, uncontaminated pumped ground water, foundation or footing drains (not including active groundwater dewatering systems), crawl space pumps, air conditioning condensation, springs, non-commercial washing of vehicles, natural riparian habitat or wet-land flows, swimming pools (if dechlorinated - typically less than one PPM chlorine), fire-fighting activities, and any other water source not containing pollutants.

### **15. Prohibition of Illicit Connections**

The construction, use, maintenance or continued existence of illicit connections to the storm drain system is prohibited. This prohibition expressly includes, without limitation, any illicit connections made in the past. This is regardless of whether the connection was permissible under law or practices applicable or prevailing at the time of connection. A

person is considered to be in violation if the person connects a line conveying sewage to the MS4, or allows such a connection to continue.

### **16. Notification of Spills or Illicit Discharges**

Notwithstanding other requirements by law, as soon as any contractor has information regarding any known or suspected release of materials that result or may result in illegal discharges or pollutants discharging into storm water, the storm drain system, campus waterways said person shall take all necessary steps to ensure the discovery, immediate containment, and cleanup of such release. **In the event of a release of hazardous materials or upon observing an illicit environmental discharge immediately contact the Towson University Police Department (TUPD) at (410) 704-4444.** In the event of a release of non-hazardous materials, notify Towson University Environmental Health & Safety in person or by phone [(410) 704-2949] or e-mail [safety@towson.edu](mailto:safety@towson.edu) no later than the next business day. Notifications in person or by phone shall be confirmed by written notice addressed and mailed to Environmental Health & Safety, Towson University, 8000 York Road, Towson, MD 21252 within three business days of the phone notice.

### **17. Enforcement**

**a.** Enforcement for student violators will follow the TU Office of Student Conduct and Civility Educations *Code of Student Conduct*.

**b.** Enforcement for University employees (Faculty and Staff) shall follow the Towson University Policy for discipline or termination *Policy No. 07.05.25 – Disciplinary Action for Employees*.

**c.** Enforcement for Visitors (Non-TU Faculty, Staff, Students or Contractors)

**d.** Individuals or Contractors, depending on the nature and severity of the violation, may be referred to MDE for prosecution for violation of federal and state laws and regulations.

**e.** Any fines, penalties, environmental monitoring or remediation expenses, etc., resulting from the illicit discharge, will be violator's responsibility.

**f.** During normal University business hours (Monday-Friday, 8am- 4pm), contact EHS at (410) 704-2949 to report violations.

**g.** If the violator is still on the scene, they should also immediately contact TUPD at (410) 704-4444.

**h.** After normal duty hours, weekends and holidays, contact TUPD at (410) 704-4444 to report violations.

The provisions contained in this exhibit will be incorporated and be a part of the contract entered into between Towson University and any contractors as a result of this procurement.

**1. Affirmation - Contingent Fees**

The Contractor shall submit with its bid/proposal a Procurement Affirmation regarding contingent fees in the form required by USM Procurement Policies and Procedures.

**2. Affirmation - Debarment**

The Contractor shall submit with its bid/proposal a Procurement Affirmation in the form required by USM Procurement Policies and Procedures.

**3. Affirmation Regarding Debarment of Related Entities**

The Contractor shall submit with its bid/proposal a Procurement Affirmation regarding debarment of related entities in the form required by USM Procurement Policies and Procedures.

**4. Affirmation - Non-Collusion**

The Contractor shall submit with its bid/proposal a Non-Collusion Affirmation in the form required by USM Procurement Policies and Procedures.

**5. Affirmation Regarding Bribery Convictions**

The offeror warrants that neither it nor any of its officer, directors, or partners nor any of its employees who are directly involved in obtaining or performing contracts with any public body has been convicted of bribery, attempted bribery, or conspiracy to bribe under the laws of any state or of the federal government or has engaged in conduct since July 1, 1977, which would constitute bribery, attempted bribery, or conspiracy to bribe under the laws of any state or the federal government.

The Contractor shall submit with its bid/proposal a Procurement Affirmation regarding bribery convictions in the form required by University System of Maryland (USM) Procurement Policies and Procedures.

**6. Affirmation Regarding Other Convictions**

The Contractor shall submit with its bid/proposal a Procurement Affirmation regarding other convictions in the form required by USM Procurement Policies and Procedures.

**7. Affirmation Regarding Sub-Contractors**

The Contractor shall submit with its bid/proposal a Procurement Affirmation regarding debarment of sub-contractors in the form required by USM Procurement Policies and Procedures.

**8. Affirmation - Drug and Alcohol Free Workplace**

The contractor warrants that the contractor shall comply with COMAR 21.11.08 Drug and Alcohol Free Workplace, and that

the contractor shall remain in compliance throughout the term of this contract.

**9. Certification of Corporation Registration and Tax Payment**

The Contractor shall submit with its bid/proposal a Procurement Affirmation regarding certification of corporation registration and tax payment in the form required by USM Procurement Policies and Procedures.

**10. Affirmation - Financial Disclosure**

The Contractor shall submit with its bid/proposal a Financial Disclosure Affirmation in the form required by USM Procurement Policies and Procedures.

**11. Affirmation - Political Contribution Disclosure**

The Contractor shall submit with its bid/proposal a Political Contribution Disclosure Affirmation in the form required by USM Procurement Policies and Procedures.

**12. Contract Affidavit**

The successful bidder shall submit, prior to contract award, a Contract Affidavit in the form required by USM Procurement Policies and Procedures.

**13. Affirmative Action**

The Contractor and all subcontractors shall develop and maintain affirmative action plans directed at increasing the utilization of women and members of minority groups on State public works projects, pursuant to the Executive Order 11246 of the President of the United States of America and guidelines on Affirmative Action issued by the Equal Employment Opportunities Commission (EEOC) 29 C.F.R. part 1608 and the Governor of Maryland's Executive Order 01.01.1993.16.

**14. Amendments and Modifications**

The contract documents, as defined within the contract, constitute the entire agreement between the parties hereto. All other communications between the parties prior to execution of the contract, whether written or oral, with reference to the subject matter of the contract are superseded by the agreement contained therein. No amendment of this contract shall be binding unless in writing and signed by the parties. Amendments may not significantly change the scope of the contract.

**15. Civil Rights Act of 1964**

Contractors providing materials, equipment, supplies or services to the State under the contract herewith assure the State that they are conforming to the Civil Rights Act of 1964, the Civil Rights Restoration Act of 1988, the Civil Rights Act of 1991, and Section 202 of Executive Order 11246 of the President of the United States of America as amended by Executive Order 11375, as applicable.

## 16. Compliance with Laws

The Contractor hereby represents and warrants that:

- a. It is qualified to do business in the State of Maryland, and that it will take such action, as from time to time hereafter, may be necessary to remain so qualified;
- b. It is not in arrears with respect to the payment of any monies and owing the State of Maryland, or any department or agency thereof, including but not limited to the payment of taxes and employee benefits, and that it shall not become so in arrears during the term of the contract;
- c. It shall comply with all federal, State and local laws, ordinances applicable to its activities and obligations under the contract; and;
- d. It shall procure, at its expense, all licenses, permits, insurance and governmental approval, if any, necessary to the performance of its obligations under the contract.

## 17. Compensation and Method of Payment

Contractor agrees to include on the face of all invoices billed to the University, its Taxpayer Identification Number, which is the Social Security Number for individuals and sale proprietors and the Federal Employee Identification Number for all other types of organizations.

## 18. Confidentiality; dissemination of Information

Contractor shall not release any information related to services or performance of the services under this Contract, nor publish any final reports or documents without the prior written approval of the University. Contractor shall indemnify and hold harmless the State and the University, its officers, agents and employees from all harm which may be incurred by reason of dissemination, publication, distribution or circulation, in any manner whatsoever, of any information, data, documents, or materials pertaining in any way to this Contract by Contractor, its agents or employees.

## 19. Conflict of Interest Law

It is unlawful for any State officer, employee, or agent to participate personally in his official capacity through decision, approval, disapproval, recommendation, advice, or investigation in any contract or other matter in which he, his spouse, parent, child, brother, or sister has a financial interest or to which any firm, corporation, association, or other organization in which he has a financial interest or in which he is serving as an officer, director, trustee, partner, or employee, or any person or organization with whom he is negotiating or has any arrangement concerning prospective employment, is a party, unless such officer, employee, or agent has previously complied with the provisions of State Government Article §§ 15-501 et seq. of the Annotated Code of Maryland.

## 20. Contract Modifications and Changes

- a. The procurement officer unilaterally may, at any time, without notice to the sureties, if any, by written order designed or indicated to be a change order, make any change

in work within the general scope of the contract, including but not limited to changes:

- (1) In the specifications (including drawings and designs);
- (2) In the method or manner of performance of the work;
- (3) In the State-furnished facilities, equipment, materials, services, or site; or
- (4) Directing acceleration in the performance of the work.
- b. Any other written order or an oral order, including a direction, instruction, interpretation or determination, from the procurement officer that causes any such change, shall be treated as a change order under this clause, provided that the Contractor gives the procurement officer written notice stating the date, circumstances, and source of the order and that the Contractor regards the order as a change order.
- c. Except as herein provided, no order, statement, or conduct of the procurement officer shall be treated as a change under this clause or entitle the Contractor to an equitable adjustment hereunder.
- d. Subject to paragraph f., if any change under this clause causes an increase or decrease in the Contractor's cost of, or the time required for, the performance of any part of the work under this contract, whether or not changed by any order, an equitable adjustment shall be made and the contract modified in writing accordingly; provided, however, that except for claims based on defective specifications, no claim for any change under (b.) above shall be allowed for any costs incurred more than 20 days before the Contractor gives written notice as therein required; and provided further, that in the case of defective specifications for which the State is responsible, the equitable adjustment shall include any increased cost reasonably incurred by the Contractor in attempting to comply with such defective specifications.
- e. If the Contractor intends to assert a claim for an equitable adjustment under this clause, he shall, within 30 days after receipt of a written change order under a. above or the furnishing or written notice under b. above, submit to the procurement officer a written statement setting forth the general nature and monetary extent of such claim, unless this period is extended by the University. The statement of claim hereunder may be included in the notice under b. above.
- f. Each contract modification or change order that affects contract price shall be subject to the prior written approval of the procurement officer and other appropriate authorities and to prior certification of the appropriate fiscal authority of fund availability and the effect of the modification or change order on the project budget or the total construction cost. If, according to the certification of the fiscal authority, the contract modification or change order will cause an increase in cost that will exceed budgeted and available funds, the modification or change order may not be made unless sufficient additional funds are made available or the scope of the project is adjusted to permit its completion within the project budget.

g. No claim by the Contractor for an equitable adjustment hereunder shall be allowed if asserted after final payment under the contract.

### **21. Contractor's On-Site Representative**

The Contractor is required to maintain on site at all times when the work is in progress on this project an individual who represents the Contractor, is responsible for the entire project, and can communicate in English with the University's representative.

### **22. Contractor's Invoices**

Contractor shall include its Taxpayer Identification Number on the face of each invoice billed to the University. If a Purchase Order document is issued, the Purchase Order Number must be included.

### **23. Cooperation with University and State Representatives**

Before any of the work shall begin, the Contractor shall confer with the University's representative at the site and agree on a sequence of procedure, means of access to the premises, space for storage of materials and equipment, use of approaches, use of facilities, etc.

### **24. Cost and Price Certification**

The Contractor, by submitting cost or price information certifies that, to the best of its knowledge, the information submitted is accurate, complete, and current as of a mutually determined specified date prior to the conclusion of any price discussions or negotiations for:

a. A negotiated contract, if the total contract price is expected to exceed \$100,000 or a smaller amount set by the procurement officer; or

b. A change order or contract modification, expected to exceed \$100,000 or a smaller amount set by the procurement officer.

c. The price under this contract and any change order or modification hereunder, including profit or fee, shall be adjusted to exclude any significant price increases occurring because the Contractor furnished cost or price information which, as of the date agreed upon between the parties, was inaccurate, incomplete, or not current.

### **25. Default Delay and Time Extension**

Termination for Default — Damages for Delay — Time Extensions

(1) If the Contractor refuses or fails to prosecute the work, or any separable part thereof, with such diligence as shall insure its completion within the time specified in this contract, or any extension thereof, or fails to complete said work within this time, the State may, by written notice to the Contractor, terminate his right to proceed with the work or the part of the work as to which there has been delay. In this event the State may take over the work and prosecute the same to completion, by contract or otherwise, and may take possession of and utilize in completing the work the

materials, appliances, and plant as may be on the site of the work and necessary therefor. Whether or not the Contractor's right to proceed with the work is terminated, he and his sureties shall be liable for any damage to the State resulting from his refusal or failure to complete the work within the specified time.

(2) If fixed and agreed, liquidated damages are provided in the contract, and if the State so terminates the Contractor's right to proceed, the resulting damage shall consist of such liquidated damages until a reasonable time as may be required for final completion of the work together with any increased costs occasioned the State in completing the work.

(3) If fixed and agreed liquidated damages are provided in the contract and if the State does not so terminate the Contractor's right to proceed, the resulting damage shall consist of these liquidated damages until the work is completed or accepted.

(4) The Contractor's right to proceed may not be so terminated nor the contractor charged with resulting damages if:

(a) The delay in the completion of the work arises from unforeseeable causes beyond the control and without the fault or negligence of the Contractor, including but not restricted to, acts of God, acts of the public enemy, acts of the State in either its sovereign or contractual capacity, acts of another Contractor in the performance of a contract with the State, fires, floods, epidemics, quarantine restrictions, strikes, freight embargoes, unusually severe weather, or delays of subcontractors or suppliers arising from unforeseeable causes beyond the control and without the fault or negligence of both the Contractor and the subcontractors or suppliers; and

(b) The Contractor, within 10 days from the beginning of any such delay (unless the procurement officer grants a further period of time before the date of final payment under the contract), notifies the procurement officer in writing of the causes of delay. The procurement officer shall ascertain the facts and the extent of the delay and extend the time for completing the work when, in his judgement, the findings of fact justify such an extension, and his findings of fact shall be final and conclusive on the parties, subject only to appeal as provided in the "Disputes" clause of this contract.

(5) If, after notice of termination of the Contractor's right to proceed under the provisions of this clause, it is determined for any reason that the Contractor was not in default under the provisions of this clause, or that the delay was excusable under the provisions of this clause, the rights and obligations of the parties shall, if the contract contains a clause providing for termination for convenience of the State, be the same as if the notice of termination had been issued pursuant to the clause. If, in the foregoing circumstances, this contract does not contain a clause providing for termination for convenience of the State, the contract shall be equitably adjusted to compensate for the termination and the contract modified accordingly; failure to agree to any such adjustment



shall be a dispute concerning a question of fact within the meaning of the clause of this contract entitled "Disputes".

(6) The rights and remedies of the State provided in this clause are in addition to any other rights and remedies provided by law or under this contract.

(7) As used in paragraph (4)(a) of this clause, the term "subcontractors or suppliers" means subcontractors or suppliers at any tier."

## **26. Delivery and Acceptance**

Delivery shall be made in accordance with the specifications. The University reserves the right to test any materials, equipment, supplies, or services delivered to determine if the specifications have been met. The materials listed in the specifications shall be delivered FOB the point or points specified prior to or on the date specified in the solicitation. Any material that is defective or fails to meet the terms of the specifications may be rejected. Rejected materials shall be promptly replaced. The State reserves the right to purchase replacement materials in the open market. Vendors failing to promptly replace materials lawfully rejected shall be liable for any excess price paid for the replacement, plus applicable expenses, if any.

## **27. Disputes**

a. This contract is subject to the USM Procurement Policies and Procedures.

b. Except as otherwise provided in this contract or by law, all disputes arising under or as a result of a breach of this contract that are not disposed of by mutual agreement shall be resolved in accordance with this clause.

c. As used herein, claim means a written demand or assertion by one of the parties seeking, as a legal right, the payment of money, adjustment or interpretation of contract terms, or other relief, arising under or relating to this contract. A voucher, invoice, or request for payment that is not in dispute when submitted is not a claim under this clause. However, if the submission subsequently is not acted upon in a reasonable time, or is disputed as to liability or amount, it may be converted to a claim for the purpose of this clause.

d. Within 30 days after contractor knows or should have known of the basis for a claim relating to this contract, contractor shall file a written notice of claim with the procurement officer.

e. Contemporaneously with, or within 30 days after, the filing of a notice of claim, contractor shall submit the written claim to the procurement officer. If contractor so requests, the procurement officer, on conditions the procurement officer deems satisfactory to the unit, may extend the time in which contractor must submit the claim. An example of when a procurement officer may grant an extension includes situations in which the procurement officer finds that a contemporaneous or timely cost quantification following the filing of the notice of claim is impossible or impractical.

f. The claim shall set forth all the facts surrounding the controversy. Contractor, at the discretion of the procurement officer, may be afforded an opportunity to be heard and to offer evidence in support of the claim.

g. The procurement officer shall mail or deliver written notification of the final decision within:

(1) 90 days after the procurement officer receives the claim if the claim is an amount for which the Appeals Board accelerated procedure, set forth in COMAR 21.10.06.12, may be used;

(2) 180 days after the procurement officer receives the claim for a claim not covered under §G(1) of this regulation; or

(3) A longer period that the procurement officer and contractor agree to in writing.

h. The final decision may award a contract claim only for those expenses incurred not more than 30 days before contractor was initially required to have filed the notice of claim.

i. The procurement officer's decision is the final action of the University. If the procurement officer fails to render a final decision within the time required, contractor may deem the failure to be a final decision not to pay the claim.

j. If the final decision grants the claim in part and denies the claim in part, the University shall pay contractor the undisputed amount. Payment of the partial claim is not an admission of liability by the University and does not preclude the University from recovering the amount paid if a subsequent determination modifies the final decision.

k. Contractor may file a written appeal with the Maryland State Board of Contract Appeals within 30 days of receipt of notice of the decision.

l. Pending resolution of a claim, contractor shall proceed diligently with the performance of the contract in accordance with the procurement officer's decision.

## **28. EPA Compliance**

Materials, supplies, equipment and services shall comply in all respects with the federal Noise Control Act of 1972, where applicable. Power equipment, to the greatest extent possible, shall be the quietest available. Equipment certified by the US EPA as a Low Noise Emission Product pursuant to the Federal Noise Control Act of 1972 shall be considered to meet the intent of the regulation.

The Contractor must supply and have immediately available to their employees spill containment equipment/supplies necessary to contain any hazards it may introduce to the job site. The Contractor is responsible for any and all costs incurred by the University in remediating spills or releases of materials introduced onto the job site.

Depending on the nature of the contract, the additional environmental and safety provisions contained in Exhibit A-1 may also be required

### **29. FERPA**

The Parties agree to maintain the privacy and security of personally identifiable educational records and health information and to prevent disclosure in compliance with Federal laws.

### **30. Gramm-Leach-Bliley Act of 1999**

The Contractor agrees that in performing its obligations under this contract, the Contractor shall comply with all requirements of a non-affiliated third-party who receives a financial institution's consumer or customer information, under the Gramm-Leach-Bliley Act of 1999 and applicable regulations thereto (the "GLB Act") and other applicable federal and state consumer privacy acts, rules and regulations. Nonpublic personal information shall have the same meaning as that term is defined in the GLB Act.

**a.** The Contractor agrees to disclose such nonpublic personal information for the sole purpose of facilitating the Contractor's performance of its duties and obligations under the contract and will not disclose such nonpublic personal information to any other party unless such disclosure is (i) allowed by the GLB Act and consented to by the University, or (ii) compelled by law, in which case the Contractor will provide notice of such disclosure to the University.

**b.** The Contractor represents and warrants that it will, for so long as it retains nonpublic personal information, implement and maintain in place the necessary information security policies and procedures for (i) protecting the confidentiality of such nonpublic personal information, (ii) protecting against any anticipated threats or hazards to the security or integrity of such nonpublic personal information, and (iii) protecting against the unauthorized access to or use of such nonpublic personal information. These terms apply to all subcontractors employed by the Contractor who perform work under the scope of the agreement.

If the Contractor's price includes the cost of Contractor furnishing any other material, equipment, supplies, or other items in connection with the Contract, the Contractor shall pay the Maryland sales tax.

### **31. Incorporation by Reference**

The terms of this solicitation and any amendments thereto are made a part of this Contract.

### **32. Indemnification**

The University shall not assume any obligation to indemnify, hold harmless, or pay attorneys' fees that may arise from or in any way be associated with the performance or operation of this agreement.

### **33. Inspection by the University**

The University may provide for inspection, at any time, of any part of the Contractor's work, and of any of the materials, supplies or equipment which the Contractor may have on

hand or in the building. The Contractor shall provide adequate cooperation with any inspector assigned by the University to permit the inspector to determine the Contractor's conformity with these specifications and the adequacy of the work being performed.

### **34. Intellectual Property**

Contractor agrees to indemnify and save harmless the University, its officers, agents and employees with respect to any claim, action, cost or judgment for patent infringement, or trademark or copyright violation arising out of purchase or use of materials, supplies, equipment or services covered by the contract.

### **35. I-9 Requirement**

Contractor warrants and represents that it is currently in compliance, and that during the term of the contract it will remain in compliance, with the Immigration Reform and Control Act of 1986, and that it will obtain original valid employment verification documentation from all its employees on a timely basis as required by law and regulation. This requirement also applies to all subcontractors hired by Contractor.

### **36. Insurance and Indemnification Provisions**

**a.** The Contractor shall defend, indemnify and save harmless the University System of Maryland, its officers, employees and agents, from any and all claims, liability, losses and causes of actions which may arise out of the performance by the Contractor, employees or agents, of the work covered by the contract.

**b.** The Contractor shall secure, pay the premiums for, and keep in force until the expirations of the contract, and any renewal thereof, adequate insurance as provided below, such insurance to specifically include liability assumed by the Contractor under the contract.

**(1)** Commercial General Liability Insurance including all extensions:  
\$2,000,000 each occurrence;  
\$2,000,000 personal injury;  
\$2,000,000 products/completed operations;  
\$2,000,000 general aggregate

**(2)** Workmen's Compensation Insurance and Unemployment Insurance as required by the laws of the State of Maryland.

**(3)** If automotive equipment is used in the operation, automobile liability insurance of \$1,000,000 combined single limit, each accident.

**c.** Each policy for liability protection, bodily injury or property damage must specifically name, on its face, Towson University, as an additional named insured as respects operations under the contract and premises occupied by the Contractor provided, however, with respect to the Contractor's liability for bodily injury or property damage under items b(1) b(4) above, such insurance shall cover and not exclude Contractor's liability for injury to the property of

the University System and to the persons or property of employees, students, faculty members, agents, officers, regents, invitees or guests of the University System.

d. Each insurance policy shall contain the following endorsements: "It is understood and agreed that the Insurance Company shall notify in writing procurement officer forty-five (45) days in advance of the effective date of any reduction in or cancellation of this policy." A certificate of each policy of insurance shall be furnished to the procurement officer. With the exception of Workmen's Compensation, upon the request of the procurement officer, a certified true copy of each policy of insurance, including the above endorsement, manually countersigned by an authorized representative of the insurance company, shall be furnished to the procurement officer. A certificate of insurance for Workmen's Compensation together with a properly executed endorsement for cancellation notice shall also be furnished. Following the notice of contract award, the requested certificates and policies shall be delivered as directed by the procurement officer. Notices of policy changes shall be furnished to the procurement officer.

e. All required insurance coverages must be acquired from insurers authorized to do business in the State of Maryland and acceptable to the University. The insurers must have a policyholders' rating of "A-" or better, and a financial size of "Class VII" or better in the latest edition of Best's Insurance Reports.

### **37. Fire and Extended Coverage Insurance**

a. Contractor shall carry, at its own expense, builder's risk insurance for the full contract amount, insuring against the perils of fire, lightning, extended coverage vandalism, and malicious mischief subject only to the minimum standard deductible currently filed by the Insurance Service Office with the State of Maryland Insurance Department. The University will provide no coverage during the construction period.

b. The builder's risk policy shall contain endorsements reading as follows:

(1) It is the intent of this insurance to cover specifically all the Work being done under the Contract between the insureds, and as to such Work this policy shall be primary insurance and shall not contribute or claim contribution from any other insurance being carried which, by its terms, would also cover the property covered hereunder in the absence of this insurance.

(2) Coverage afforded under this policy will not be canceled until at least fifteen (15) days prior written notice has been given to the Procurement Officer.

c. Certificates of insurance shall be submitted to the Procurement Officer for review and approval prior to commencement of work, and shall be held for the duration of the contract. The University shall have the absolute right to terminate the contract if the policy of insurance is canceled

at any time for any reason and a new policy is not obtained by Contractor and approved by the Procurement Officer.

d. The above insurance shall remain in full force and effect until such time as the University shall fully accept the work covered by this contract.

### **38. Liquidated Damages**

Time is an essential element of the contract and it is important that the work be vigorously prosecuted until completion.

For each day that any work shall remain uncompleted beyond the time(s) specified elsewhere in the contract, the Contractor shall be liable for liquidated damages in the amount(s) provided for in the solicitation, provided, however, that due account shall be taken of any adjustment of specified completion time(s) for completion of work as granted by approved change orders.

### **39. Local Conditions Covering Work**

The Contractor shall cooperate with those in authority on the premises to prevent the entrance and exit of all workmen and/or others whose presence is forbidden or undesirable and in bringing, storing or removal of all materials and equipment, to observe all rules and regulations in force on the grounds, to avoid unnecessary dust or accumulated debris or the undue interference with the convenience, sanitation or routine of the University and to prevent the loss of, or damage to the property of the University and/or its employees. The Contractor shall repair any and all damage he may cause to the building or property, to the full satisfaction of the University.

### **40. Mandated Contractor Reporting of Suspected Child Abuse & Neglect**

Maryland law contains mandatory reporting requirements for all individuals who suspect child abuse or neglect. Contractors performing work on campus also must comply with USM Board of Regents (BOR) VI-1.50 – Policy on the Reporting of Suspected Child Abuse & Neglect, as well as the University Procedures for Reporting Suspected Child Abuse and Neglect. The above-referenced USM/University Policy and Procedures are available in full at the following link: <https://www.towson.edu/about/administration/policies/documents/policies/06-01-50-policy-on-the-reporting-of-suspected-child-abuse-and-neglect.pdf>, and are incorporated herein. The University reserves the right to terminate the contract if Contractor fails to comply with the above-referenced policy or procedures, or if, in the judgment of the University, termination is necessary to protect the safety and welfare of children who come into contact with the University community.

### **41. Maryland Law Prevails**

The contract shall be governed by the laws of the State of Maryland. The parties agree that exclusive jurisdiction shall reside with the state and federal courts in the State of Maryland.

#### **42. Non-Hiring of Employees**

No employee of the State of Maryland, or any department, commission, agency or branch thereof whose duties as such employee include matters relating to or affecting the subject matter of the contract, shall, while so employed, become or be an employee of the party or parties hereby contracting with the State or any department, commission, agency or branch thereof.

#### **43. Non-Discrimination**

The Contractor will comply with all applicable Federal and State laws, rules and regulations involving non-discrimination on the basis of race, color, creed, religion, national origin, age, sex, political affiliation, marital status, veteran status, condition of disability, or other non-merit factor. In addition, Towson University's policies, programs, and activities comply with federal and state laws and University System of Maryland regulations prohibiting discrimination on the basis of race, color, religion, age, national origin, sex, disability, and sexual orientation. Provisions for reasonable accommodations shall be made by the Contractor for handicapped applicants and qualified handicapped individuals.

#### **44. Non-Visual Access**

The bidder or offeror warrants that the information technology offered under this bid or proposal (1) provides equivalent access for effective use by both visual and nonvisual means; (2) will present information, including prompts used for interactive communications, in formats intended for both visual and nonvisual use; (3) if intended for use in a network, can be integrated into networks for obtaining, retrieving, and disseminating information used by individuals who are not blind or visually impaired; and (4) is available, whenever possible, without modification for compatibility with software and hardware for nonvisual access. The bidder or offeror further warrants that the costs, if any, of modifying the information technology for compatibility with software and hardware used for nonvisual access will not increase the cost of the information technology by more than 5 percent.

For purposes of this section, the phrase "equivalent access" means that the ability to receive, use and manipulate information and operate controls necessary to access and use information technology by nonvisual means. Examples of equivalent access include keyboard controls used for input and synthesized speech, Braille, or other audible or tactile means used for output.

#### **45. Ownership of Documents and Materials**

The Contractor agrees that all documents and materials including, but not limited to, reports, drawings, studies, specifications, estimates, maps, photographs, designs, graphics, mechanical, artwork, and computations prepared by or for it under the terms of the contract shall at anytime during the performance of the services be made available to the University upon request by the University and shall become and remain the exclusive property of the University upon termination or completion of the services. The

University shall have the right to use same without restriction or limitation and without compensation to the Contractor other than that provided by the contract. The University shall be the owner for purposes of copyright, patent or trademark registration.

#### **46. Patents, Copyrights and Trade Secrets**

**a.** If the Contractor furnishes any design, device, material, process or other item which is covered by a patent or copyright or which is proprietary to or a trade secret of another, Contractor shall obtain the necessary permission or license to use such item.

**b.** Contractor will defend or settle, at its own expense, any claim or suit against the State alleging that any such item furnished by Contractor infringes any patent, trademark, copyright, or trade secret. Contractor also will pay all damages and costs that by final judgment may be assessed against the State due to such infringement and all attorneys' fees and litigation expenses reasonably incurred by the State to defend against such a claim or suit. The obligations of this paragraph are in addition to those stated in paragraph c.

**c.** If any products furnished by Contractor become, or in Contractor's opinion are likely to become, the subject of a claim of infringement, Contractor will, at its option: (1) procure for the State the right to continue using the applicable item; (2) replace the product with a non-infringing product substantially complying with the item's specifications; or (3) modify the item so it becomes non-infringing and performs in a substantially similar manner to the original item.

#### **47. Payment Bond**

A payment bond is required for all construction contracts in excess of \$100,000 in the amount equal to at least 100 percent of the contract price. The payment bond shall be delivered by the contractor to the State not later than the time the contract is executed. If a contractor fails to deliver the required payment bond, the contractor's bid shall be rejected, its bid security shall be enforced, and award of the contract shall be made to the next lowest responsive and responsible bidder.

The required payment bond shall be in the State of Maryland form in effect at the time the contract is executed per COMAR 21.07.02.10B.

#### **48. Performance Bond**

A performance bond is required for all construction contracts in excess of \$100,000 in the amount equal to at least 100 percent of the contract price. The performance bond shall be delivered by the contractor to the University not later than the time the contract is executed. If a contractor fails to deliver the required performance bond, the contractor's bid shall be rejected, its bid security shall be enforced, and award of the contract may be made to the next lowest responsive and responsible bidder.

The required performance bond shall be in the State of Maryland form in effect at the time the contract is executed per COMAR 21.07.02.10A.

#### **49. Payment of State Obligations**

Payments to the Contractor pursuant to this contract shall be made no later than 30 days after the University's receipt of a proper invoice from the Contractor. Charges of late payment of invoices, other than as prescribed by Title 15, subtitle 1, of the State Finance and Procurement Article, Annotated Code of Maryland, or by the Public Service Commission of Maryland with respect to regulated public utilities, as applicable, are prohibited.

#### **50. Policies and Procedures**

The USM Procurement Policies and Procedures in effect on the date of execution of this Contract are applicable to this Contract.

#### **51. Responsibility of Contractor**

**a.** The Contractor shall perform the services with that standard of care, skill, and diligence normally provided by a Contractor in the performance of services similar to the services hereunder.

**b.** Notwithstanding any review, approval, acceptance or payment for the services by the University, the Contractor shall be responsible for professional and technical accuracy of its work, design drawings, specifications and other materials furnished by the Contractor under the contract.

#### **52. Prompt Payment of Subcontractors**

**a.** This contract and all subcontracts issued under this contract are subject to the provisions of State Finance and Procurement Article, §15-226, Annotated Code of Maryland. References to "undisputed amount", "prime contractor", "contractor" and "subcontractor" have the meanings stated in Section 6.2 a-d herein have the meanings state in COMAR 21.10.08.01.

**b.** A contractor shall promptly pay its subcontractors an undisputed amount to which a subcontractor is entitled for work performed under this contract within 10 calendar days after the contractor receives a progress payment or final payment for work under this contract.

**c.** If a contractor fails to make payment within the period prescribed in b., a subcontractor may request a remedy in accordance with COMAR 21.10.08.

**d.** A contractor shall include in its subcontracts for work under the contract, wording that incorporates the provisions, duties, and obligations of 6.1 a-d: State Finance and Procurement Article, §15-226, Annotated Code of Maryland; and COMAR 21.10.08.

#### **53. Responsibility for Claims and Liability**

The Contractor shall be responsible for all damage to life and property due to its activities or those of its agents or

employees, in connection with the services required under the contract. Further, it is expressly understood that the Contractor shall indemnify and save harmless the University, its officers, agents, and employees from and against all claims, suits, judgments, expenses, actions, damages and costs of every name and description, including reasonable attorney's fees and litigation expenses arising out of or resulting from the negligent performance of the services of the Contractor under the contract.

#### **54. Responsibility for Damage**

**a.** The Contractor shall repair and restore to its original condition any equipment, materials or surfaces damaged by its operations.

**b.** The Contractor shall be entirely responsible for any loss or damage to its own materials, supplies, and equipment, and to the personal property of its employees while they are in the building.

**c.** The Contractor shall be solely responsible for any damage to the building or its contents for any loss or damage to any property belonging to the University or the University employees when such loss or damage may be attributable to their actions or negligence or the actions or negligence of their employees.

#### **55. Retainage**

**a.** This section shall apply if the contractor has furnished 100 percent payment security and 100 percent performance security. The contractor and each subcontractor at any tier shall incorporate the mandatory provisions outlined below in paragraphs b. through d. of this section, into each subcontract for work related to this contract.

**b.** The contractor may not retain from any payment due a subcontractor a percent of the payment greater than the percent for retainage specified in the contract.

**c.** A subcontractor at any tier may not retain from any payment due a lower tier subcontractor a percent of the payment greater than the percent of payments retained from the subcontractor.

**d.** A contractor and a subcontractor are not prohibited, by this section from withholding an amount in addition to retainage if the contractor or subcontractor determines that a subcontractor's performance under the subcontract provides reasonable grounds for withholding an additional amount.

#### **56. Retention of Records**

The Contractor shall retain and maintain all records and documents relating to the contract for a minimum period of four years after payment by the University of the final invoice and shall make them available for inspection and audit by the State of Maryland.

#### **57. Set-Off**

The University may deduct from and set off against any amounts due and payable to the Contractor any back-charges

or damages sustained by the University by virtue of any breach of the contract by the Contractor or by virtue of the failure or refusal of the Contractor to perform the services or any part of the services in a satisfactory manner. Nothing herein shall be construed to relieve the Contractor of liability for additional costs resulting from a failure to satisfactorily perform the services.

#### **58. Site Investigation**

The Contractor acknowledges that he has investigated and satisfied himself as to the conditions affecting the work, including but not restricted to those bearing upon transportation, disposal, handling and storage of materials, availability of labor, water, electric power, roads and uncertainties of weather, river stages, tides or similar physical conditions at the site, the conformation and conditions of the ground, the character of equipment and facilities needed preliminary to and during prosecution of the work. The Contractor further acknowledges that he has satisfied himself as to the character, quality and quantity of surface and subsurface materials or obstacles to be encountered insofar as this information is reasonably ascertainable from an inspection of the site, including all exploratory work done by the University, as well as from information presented by the drawings and specifications made a part of this contract. Any failure by the Contractor to acquaint himself with the available information may not relieve him from responsibility for estimating properly the difficulty or cost of successfully performing the work. The University assumes no responsibility for any conclusions or interpretations made by the Contractor on the basis of the information made available by the University.

#### **59. Software Contracts:**

As specifically provided by § 21-104, Commercial Law Article, Annotated Code of Maryland, the parties agree that this Agreement shall not be governed by the Uniform Computer Information Transactions Act (UCITA), Title 21 of the Commercial Law Article of the Annotated Code of Maryland, as amended from time to time. This Agreement shall be governed by the common law of Maryland relating to written agreements, as well as other statutory provisions, other than UCITA, which may apply, and shall be interpreted and enforced as if UCITA had never been adopted in Maryland.

Contractor agrees that as delivered to buyer, the software does not contain any program code, virus, worm, trap door, back door, timer or clock that would erase data or programming or otherwise cause the software to become inoperable, inaccessible, or incapable of being used in accordance with its user manuals, either automatically upon the occurrence of selected conditions, or manually on command of Contractor.

#### **60. Specifications**

All materials, equipment, supplies or services shall conform to Federal and State laws and regulations and to the specifications contained in the solicitation. No asbestos, lead, or PCB-containing materials (0%) are to be utilized/installed on campus unless prior written approval has been received

from the University's Department of Environmental Health & Safety (410-704-2949).

#### **61. Subcontracting or Assignment**

The benefits and obligations hereunder shall take effect and be binding upon the parties hereto and neither the contract nor the services to be performed thereunder shall be subcontracted, or assigned or otherwise disposed of, either in whole or in part, except with the prior written consent of the University.

#### **62. Suspension of Work**

The procurement officer unilaterally may order the Contractor in writing to suspend, delay, or interrupt all or any part of the work for such period of time as he may determine to be appropriate for the convenience of the University.

#### **63. Tax Exemption**

The State is generally exempt from federal excise taxes, Maryland sales and use taxes, District of Columbia sales taxes, and transportation taxes. Exemption certificates shall be provided upon request. Where a Contractor is required to furnish and install material in the construction of improvement to real property in performance of the Contract, the Contractor shall pay the Maryland sales tax and the exemption does not apply.

#### **64. Termination of Contract for Default**

If the Contractor fails to fulfill its obligation under the contract properly and on time, or otherwise violates any provision of the contract, the University may terminate the contract by written notice to the Contractor. The notice shall specify the acts or omissions relied on as cause for termination. All finished or unfinished services provided by the Contractor shall, at the University's option, become the University's property. The University shall pay the Contractor fair and equitable compensation for satisfactory performance prior to receipt of notice of termination, less the amount of damages caused by the Contractor's breach. If the damages are more than the compensation payable to the Contractor, the Contractor will remain liable after termination and the University can affirmatively collect damages. The term "damages" as used in this paragraph may include attorney's fees and litigation costs. Termination hereunder, including the determination of the rights and obligations of the parties, shall be governed by the provisions of USM Procurement Policies and Procedures.

#### **65. Termination of Contract for Convenience**

The performance of work under the contract may be terminated by the University in accordance with this clause in whole, or from time to time in part, whenever the University shall determine that such termination is in the best interest of the University. The University will pay all reasonable costs associated with the contract that the Contractor has incurred up to the date of termination and all reasonable costs associated with termination of the contract. However, the Contractor shall not be reimbursed for any anticipatory profits which have not been earned up to the date of termination. Termination hereunder, including the determination of the rights and obligations of the parties,

shall be governed by the provisions of USM Procurement Policies and Procedures.

#### **66. Termination of Multi-Year Contracts**

If the General Assembly fails to appropriate funds or if funds are not otherwise made available for continued performance for any fiscal period of the contract succeeding the first fiscal period, the contract shall be canceled automatically as of the beginning of the fiscal year for which funds were not appropriated or otherwise made available; provided, however, that this will not affect either the State's rights or the Contractor's rights under any termination clause in the contract. The effect of termination of the contract hereunder will be to discharge both the Contractor and the State from future performance of the contract, but not from their rights and obligations existing at the time of termination. The Contractor shall be reimbursed for the reasonable value of any non-recurring costs incurred but not amortized in the price of the contract. The State will notify the Contractor as soon as it has knowledge that funds may not be available for the continuation of the contract for each succeeding fiscal period beyond the first.

#### **67. Truth-In-Negotiation Certification**

The Contractor by submitting cost or price information, including wage rates or other factual unit costs, certifies to the best of its knowledge, information and belief, that:

a. The wage rates and other factual unit costs supporting the firm's compensation, as set forth in the proposal, are accurate, complete and current as of the contract date;

b. If any of the items of compensation were increased due to the furnishing of inaccurate, incomplete or noncurrent wage rates or other units of costs, the State is entitled to an adjustment in all appropriate items of compensation, including profit or fee, to exclude any significant sum by which the price was increased because of the defective data. The State's right to adjustment includes the right to a price adjustment for defects in costs or pricing data submitted by a prospective or actual subcontractor; and

c. If additions are made to the original price of the contract, such additions may be adjusted to exclude any significant sums where it is determined the price has been increased due to inaccurate, incomplete or noncurrent wage rates and other factual costs."

#### **68. University Access to Site**

Appropriate institution officers and employees shall retain access to all institution premises, at all times, for the purpose of campus health or safety. Contractor may have access to the work area during normal business hours during the term of this Agreement and at other times as agreed upon by the Parties.

#### **69. Use of Contractor's Forms Not Binding on State**

a. Except as provided in b., the use or execution by the State of any forms, orders, agreements, or other documents of any kind, other than the contract documents, used pursuant to or in the administration of any contract awarded by the State to Contractor, shall not bind the State to any of the terms and conditions contained therein except those provisions:

(1) generally describing, for the purposes of ordering: Equipment or services to be provided, locations, quantities, delivery or installation dates, and, to the extent consistent with the contract documents, prices; and

(2) not otherwise inconsistent with the contract documents.

b. Any such form, order, agreement or other document shall not vary, modify, or amend the terms and provisions of the contract documents, notwithstanding any provision to the contrary in such document, unless all of the following conditions are met:

(1) the document expressly refers to the particular document and provision of the contract documents being modified and plainly and conspicuously identifies any modification thereto as a modification:

(2) the document is executed on behalf of the State by the procurement officer; and

(3) execution of the document is approved by the procurement authority whose approval is required by law.

#### **70. Variations in Estimated Quantities**

Where the quantity of a pay item in this contract is an estimated quantity and where the actual quantity of such pay item varies more than twenty-five percent (25%) above or below the estimated quantity stated in this contract, an equitable adjustment in the contract price shall be made upon demand of either party. The equitable adjustment shall be based upon any increase or decrease in costs due solely to the variation above one hundred twenty-five percent (125%) or below seventy-five percent (75%) of the estimated quantity. If the quantity variation is such as to cause an increase in the time necessary for completion, the procurement officer shall, upon receipt of a written request for an extension of time within ten (10) days from the beginning of the delay, or within a further period of time which may be granted by the procurement officer before the date of final settlement of the contract, ascertain the facts and make the adjustment for extending the completion date as in his judgment the findings justify.

**A. AUTHORITY**

**I HEREBY AFFIRM THAT:**

I am the (title) \_\_\_\_\_ and the duly authorized representative of (business) \_\_\_\_\_ and that I possess the legal authority to make this Affidavit on behalf of myself and the business for which I am acting.

**B. AFFIRMATION REGARDING BRIBERY CONVICTIONS**

**I FURTHER AFFIRM THAT:** Neither I, nor to the best of my knowledge, information, and belief, the above business (as is defined in Section 16-101(b) of the State Finance and Procurement Article of the Annotated Code of Maryland), or any of its officers, directors, partners, controlling stockholders, or any of its employees directly involved in the business's contracting activities including obtaining or performing contracts with public bodies has been convicted of, or has had probation before judgment imposed pursuant to Criminal Procedure Article, §6-220, Annotated Code of Maryland, or has pleaded *nolo contendere* to a charge of, bribery, attempted bribery, or conspiracy to bribe in violation of Maryland law, or of the law of any other state or federal law, except as follows (indicate the reasons why the affirmation cannot be given and list any conviction, plea, or imposition of probation before judgment with the date, court, official or administrative body, the sentence or disposition, the name(s) of person(s) involved, and current positions and responsibilities with the business):

**C. AFFIRMATION REGARDING OTHER CONVICTIONS RETAINED**

**I FURTHER AFFIRM THAT:** Neither I, nor to the best of my knowledge, information, and belief, the above business, or any of its officers, directors, partners, controlling stockholders, or any of its employees directly involved in the business's contracting activities including obtaining or performing contracts with public bodies, has:

- (1) Been convicted under state or federal statute of:
  - (a) A criminal offense incident to obtaining, attempting to obtain, or performing a public or private contract;  
or
  - (b) Fraud, embezzlement, theft, forgery, falsification or destruction of records or receiving stolen property;
- (2) Been convicted of any criminal violation of a state or federal antitrust statute;
- (3) Been convicted under the provisions of Title 18 of the United States Code for violation of the Racketeer Influenced and Corrupt Organization Act, 18 U.S.C. §1961 *et seq.*, or the Mail Fraud Act, 18 U.S.C. §1341 *et seq.*, for acts in connection with the submission of bids or proposals for a public or private contract;



- (4) Been convicted of a violation of the State Minority Business Enterprise Law, §14-308 of the State Finance and Procurement Article of the Annotated Code of Maryland;
- (5) Been convicted of a violation of §11-205.1 of the State Finance and Procurement Article of the Annotated Code of Maryland;
- (6) Been convicted of conspiracy to commit any act or omission that would constitute grounds for conviction or liability under any law or statute described in subsections (1) - (5) above;
- (7) Been found civilly liable under a state or federal antitrust statute for acts or omissions in connection with the submission of bids or proposals for a public or private contract;
- (8) Been found in a final adjudicated decision to have violated the Commercial Nondiscrimination Policy under Title 19 of the State Finance and Procurement Article of the Annotated Code of Maryland with regard to a public or private contract; or
- (9) Admitted in writing or under oath, during the course of an official investigation or other proceedings, acts or omissions that would constitute grounds for conviction or liability under any law or statute described in §§B and C and subsections D(1)–(8) above, except as follows (indicate reasons why the affirmations cannot be given, and list any conviction, plea, or imposition of probation before judgment with the date, court, official or administrative body, the sentence or disposition, the name(s) of the person(s) involved and their current positions and responsibilities with the business, and the status of any debarment):

**D. AFFIRMATION REGARDING DEBARMENT**

**I FURTHER AFFIRM THAT:** Neither I, nor to the best of my knowledge, information, and belief, the above business, or any of its officers, directors, partners, controlling stockholders, or any of its employees directly involved in the business's contracting activities, including obtaining or performing contracts with public bodies, has ever been suspended or debarred (including being issued a limited denial of participation) by any public entity, except as follows (list each debarment or suspension providing the dates of the suspension or debarment, the name of the public entity and the status of the proceedings, the name(s) of the person(s) involved and their current positions and responsibilities with the business, the grounds of the debarment or suspension, and the details of each person's involvement in any activity that formed the grounds of the debarment or suspension).

**E. AFFIRMATION REGARDING DEBARMENT OF RELATED ENTITIES**

**I FURTHER AFFIRM THAT:**

- (1) The business was not established and it does not operate in a manner designed to evade the application of or defeat the purpose of debarment pursuant to Sections 16-101, *et seq.*, of the State Finance and Procurement Article of the Annotated Code of Maryland; and
- (2) The business is not a successor, assignee, subsidiary, or affiliate of a suspended or debarred business, except as follows (indicate reasons why the affirmations cannot be given without qualification):

**F. SUB-CONTRACT AFFIRMATION**

**I FURTHER AFFIRM THAT:** Neither I, nor to the best of my knowledge, information, and belief, the above business, has knowingly entered into a contract with a public body under which a person debarred or suspended under Title 16 of the State Finance and Procurement Article of the Annotated Code of Maryland will provide, directly or indirectly, supplies, services, architectural services, construction related services, leases of real property, or construction.

**G. AFFIRMATION REGARDING COLLUSION**

**I FURTHER AFFIRM THAT:** Neither I, nor to the best of my knowledge, information, and belief, the above business has:

- (1) Agreed, conspired, connived, or colluded to produce a deceptive show of competition in the compilation of the accompanying bid or offer that is being submitted;
- (2) In any manner, directly or indirectly, entered into any agreement of any kind to fix the bid price or price proposal of the bidder or offeror or of any competitor, or otherwise taken any action in restraint of free competitive bidding in connection with the contract for which the accompanying bid or offer is submitted.

**H. CERTIFICATION OF TAX PAYMENT**

**I FURTHER AFFIRM THAT:** Except as validly contested, the business has paid, or has arranged for payment of, all taxes due the State of Maryland and has filed all required returns and reports with the Comptroller of the Treasury, the State Department of Assessments and Taxation, and the Department of Labor, Licensing, and Regulation, as applicable, and will have paid all withholding taxes due the State of Maryland prior to final settlement.

**I. CONTINGENT FEES**

**I FURTHER AFFIRM THAT:** The business has not employed or retained any person, partnership, corporation, or other entity, other than a bona fide employee, bona fide agent, bona fide salesperson, or commercial selling agency working for the business, to solicit or secure the Contract, and that the business has not paid or agreed to pay any person,

partnership, corporation, or other entity, other than a bona fide employee, bona fide agent, bona fide salesperson, or commercial selling agency, any fee or any other consideration contingent on making of the Contract.

**J. CERTIFICATION REGARDING INVESTMENTS IN IRAN**

- (1) The undersigned bidder or offeror certifies that, in accordance with State Finance & Procurement Article, §17-705:
  - (i) it is not identified on the list created by the Board of Public Works as a person engaging in investment activities in Iran as described in §17-702 of State Finance & Procurement; and
  - (ii) it is not engaging in investment activities in Iran as described in State Finance & Procurement Article, §17-702.
  
- (2) The undersigned bidder or offeror is unable to make the above certification regarding its investment activities in Iran due to the following activities:

**K. ACKNOWLEDGEMENT**

**I ACKNOWLEDGE THAT:** This Affidavit is to be furnished to the Procurement Officer and may be distributed to units of: (1) the State of Maryland; (2) counties or other subdivisions of the State of Maryland; (3) other states; and (4) the federal government. I further acknowledge that this Affidavit is subject to applicable laws of the United States and the State of Maryland, both criminal and civil, and that nothing in this Affidavit or any contract resulting from the submission of this bid or proposal shall be construed to supersede, amend, modify or waive, on behalf of the State of Maryland, or any unit of the State of Maryland having jurisdiction, the exercise of any statutory right or remedy conferred by the Constitution and the laws of Maryland with respect to any misrepresentation made or any violation of the obligations, terms and covenants undertaken by the above business with respect to (1) this Affidavit, (2) the contract, and (3) other Affidavits comprising part of the contract.

I DO SOLEMNLY DECLARE AND AFFIRM UNDER THE PENALTIES OF PERJURY THAT THE CONTENTS OF THIS AFFIDAVIT ARE TRUE AND CORRECT TO THE BEST OF MY KNOWLEDGE, INFORMATION, AND BELIEF.

\_\_\_\_\_  
**SIGNATURE OF AUTHORIZED REPRESENTATIVE & AFFIANT** \_\_\_\_\_  
**DATE**

\_\_\_\_\_  
**PRINT NAME OF AUTHORIZED REPRESENTATIVE & AFFIANT**

\_\_\_\_\_  
**TITLE OF AUTHORIZED REPRESENTATIVE & AFFIANT**

**A. AUTHORIZED REPRESENTATIVE**

**I HEREBY AFFIRM THAT:**

I am the (title) \_\_\_\_\_ and the duly authorized representative of (business) \_\_\_\_\_ and that I possess the legal authority to make this Affidavit on behalf of myself and the business for which I am acting.

**B. CERTIFICATION OF CORPORATION REGISTRATION AND TAX PAYMENT OR QUALIFICATION WITH THE STATE DEPARTMENT OF ASSESSMENTS AND TAXATION**

**I FURTHER AFFIRM THAT:** The business named above is a (X applicable items):

- (1)  Corporation  domestic (i.e., organized in Maryland) or  foreign;
- (2)  Limited Liability Co.  domestic or  foreign;
- (3)  Partnership  domestic or  foreign;
- (4)  Statutory Trust  domestic or  foreign;
- (5)  Sole Proprietorship

and is registered or qualified as required under Maryland law.

I further affirm that the above business is in good standing both in Maryland and (IF APPLICABLE) in the jurisdiction where it is presently organized, and has filed all of its annual reports, together with filing fees, with the Maryland State Department of Assessments and Taxation. The name and address of its resident agent (IF APPLICABLE) filed with the State Department of Assessments and Taxation is:

Name & Department ID Number: \_\_\_\_\_

Address: \_\_\_\_\_

and that if it does business under a trade name, it has filed a certificate with the State Department of Assessments and Taxation that correctly identifies that true name and address of the principal or owner as:

Name & Department ID Number: \_\_\_\_\_

Address: \_\_\_\_\_

**C. FINANCIAL DISCLOSURE AFFIRMATION**

**I FURTHER AFFIRM THAT:** I am aware of, and the above business will comply with, the provisions of Section 13-221 of the State Finance and Procurement Article of the Annotated Code of Maryland, which require that every business that enters into contracts, leases, or other agreements with the State of Maryland or its agencies during a calendar year under which the business is to receive in the aggregate \$100,000 or more shall, within 30 days of the time when the aggregate value of the contracts, leases, or other agreements reaches \$100,000, file with the Secretary of State of Maryland certain specified information to include disclosure of beneficial ownership of the business.

## **D. POLITICAL CONTRIBUTION DISCLOSURE AFFIRMATION**

**I FURTHER AFFIRM THAT:** I am aware of, and the above business will comply with, Election Law Article, §§14-101 through 14-108, Annotated Code of Maryland, which requires that every person that enters into contracts, leases, or other agreements with the State of Maryland, including its agencies or a political subdivision of the State valued at \$200,000 or more, shall file with the State Board of Elections a statement disclosing contributions in excess of \$500 made during the reporting period to a candidate for elective office in any primary or general election.

## **E. DRUG AND ALCOHOL FREE WORKPLACE**

### **I CERTIFY THAT:**

- (1) Terms defined in COMAR 21.11.08 shall have the same meanings when used in this certification.
- (2) By submission of its bid or offer, the business, if other than an individual, certifies and agrees that, with respect to its employees to be employed under a contract resulting from this solicitation, the business shall:
  - (a) Maintain a workplace free of drug and alcohol abuse during the term of the contract;
  - (b) Publish a statement notifying its employees that the unlawful manufacture, distribution, dispensing, possession, or use of drugs, and the abuse of drugs or alcohol is prohibited in the business's workplace and specifying the actions that will be taken against employees for violation of these prohibitions;
  - (c) Prohibit its employees from working under the influence of drugs or alcohol;
  - (d) Not hire or assign to work on the contract anyone whom the business knows, or in the exercise of due diligence should know, currently abuses drugs or alcohol and is not actively engaged in a bona fide drug or alcohol abuse assistance or rehabilitation program;
  - (e) Promptly inform the appropriate law enforcement agency of every drug-related crime that occurs in its workplace if the business has observed the violation or otherwise has reliable information that a violation has occurred;
  - (f) Establish drug and alcohol abuse awareness programs to inform its employees about:
    - (i) The dangers of drug and alcohol abuse in the workplace;
    - (ii) The business's policy of maintaining a drug and alcohol free workplace;
    - (iii) Any available drug and alcohol counseling, rehabilitation, and employee assistance programs; and
    - (iv) The penalties that may be imposed upon employees who abuse drugs and alcohol in the workplace;
  - (g) Provide all employees engaged in the performance of the contract with a copy of the statement required by §(2)(b), above;
  - (h) Notify its employees in the statement required by §(2)(b) above, that as a condition of continued employment on the contract, the employee shall:
    - (i) Abide by the terms of the statement; and
    - (ii) Notify the employer of any criminal drug or alcohol abuse conviction for an offense occurring in the workplace not later than 5 days after a conviction;
  - (i) Notify the procurement officer within 10 days after receiving notice under §(2)(h)(ii), above, or otherwise receiving actual notice of a conviction;

(j) Within 30 days after receiving notice under §(2)(h)(ii) above, or otherwise receiving actual notice of a conviction, impose either of the following sanctions or remedial measures on any employee who is convicted of a drug or alcohol abuse offense occurring in the workplace:

(i) Take appropriate personnel action against an employee, up to and including termination; or

(ii) Require an employee to satisfactorily participate in a bona fide drug or alcohol abuse assistance or rehabilitation program; and

(k) Make a good faith effort to maintain a drug and alcohol free workplace through implementation of §(2)(a) through (j), above.

(3) If the business is an individual, the individual shall certify and agree as set forth in §(4), below, that the individual shall not engage in the unlawful manufacture, distribution, dispensing, possession, or use of drugs or the abuse of drugs or alcohol in the performance of the contract.

(4) I acknowledge and agree that:

(a) The award of the contract is conditional upon compliance with COMAR 21.11.08 and this certification;

(b) The violation of the provisions of COMAR 21.11.08 or this certification shall be cause to suspend payments under, or terminate the contract for default under COMAR 21.07.01.11 or 21.07.03.15, as applicable; and

(c) The violation of the provisions of COMAR 21.11.08 or this certification in connection with the contract may, in the exercise of the discretion of the Board of Public Works, result in suspension and debarment of the business under COMAR 21.08.03.

**F. CERTAIN AFFIRMATIONS VALID**

**I FURTHER AFFIRM THAT:**

To the best of my knowledge, information, and belief, each of the affirmations, certification, or acknowledgments contained in that certain Bid/Proposal Affidavit dated \_\_\_\_\_ and executed by me for the purpose of obtaining the contract to which this Exhibit is attached remains true and correct in all respects as if made as of the date of this Contract Affidavit and is fully set forth herein.

I DO SOLEMNLY DECLARE AND AFFIRM UNDER THE PENALTIES OF PERJURY THAT THE CONTENTS OF THIS AFFIDAVIT ARE TRUE AND CORRECT TO THE BEST OF MY KNOWLEDGE, INFORMATION, AND BELIEF.

\_\_\_\_\_  
**SIGNATURE OF AUTHORIZED REPRESENTATIVE & AFFIANT**

\_\_\_\_\_  
**DATE**

\_\_\_\_\_  
**PRINT NAME OF AUTHORIZED REPRESENTATIVE & AFFIANT**

\_\_\_\_\_  
**TITLE OF AUTHORIZED REPRESENTATIVE & AFFIANT**

This Agreement made the \_\_\_\_\_ day of \_\_\_\_\_, Two Thousand and \_\_\_\_\_, by and between \_\_\_\_\_, herein called "Contractor" and Towson University, herein called "University." Witnesseth, that the Contractor and the University, for the consideration here mentioned agree as follows:

**Article 1. Scope of Contract** – The Contractor shall furnish all materials and perform all of the work described in the Contract Documents, and shall comply with all of the terms and conditions of the Contract Documents, all of which are made a part hereof and are referred to herein as "the Contract."

**Article 2. Contract Documents** – The Contract between the parties is set forth in the Contract Documents which consist of the following, listed in their order of precedence:

- A. This Contract,
- B. Towson University – Request for Proposal, for the Procurement of \_\_\_\_\_, Towson University, RFP No. \_\_\_\_\_ including all attachments, exhibits, and addenda, and subsequent Purchase Order, and
- C. Contractor's Proposal dated \_\_\_\_\_, submitted in response to the RFP (hereinafter referred to as the "Proposal").

In the event of a conflict between the terms and conditions of any of the Contract Documents, the controlling terms and conditions shall be in the above listed order of precedence.

**Article 3. Services** – The Contractor's performance under this Contract shall be in accordance with the requirements generally set forth in the RFP and specifically described in Section V., Specifications and as set forth in the Contractor's Technical Proposal.

**Article 4. Term of Contract** – The term of the contract shall be one year from the date that the University provides the Contractor with a Notice to Proceed. The University shall have the option to exercise four annual renewal options, said options to be exercised at the sole discretion of the University. Should the University elect to renew the contract, all prices, terms and conditions will remain in effect.

**Article 5. Contract Price** – The University shall pay the Contractors as follows:

Total Project Cost \$ \_\_\_\_\_

**Article 6. Payment of State Obligations** – Contractor will be paid for services rendered in accordance with the terms and conditions of the Contract Documents and upon submission of proper invoices submitted to the Towson University, Accounts Payable Office. The Contractor's Federal Identification Number and the University's Purchase Order number must be included on all invoices. Towson University is exempt from the payment of taxes and shall provide the Contractor with a copy of tax-exempt certificate upon request.

Electronic funds will be used by the State to pay Contractor for this Contract and any other State payments due Contractor unless the State Comptroller's Office grants Contractor an exemption.

**Article 7. Limitation of Liability** – The University shall not be liable for any indirect, special or consequential damages, such as loss of anticipated profits or other economic loss in connection with or arising out of the services provided in the Contract.

**Article 8. Assignment** – University may assign this Contract with Contractor's written consent, which shall not be unreasonably withheld.

**Article 9. Entire Agreement** – This Contract, including all Contract Documents, constitutes the entire agreement between the University and the Contractor. No waiver, modification or amendment of any of the terms or conditions hereof shall be effective unless set forth in writing and duly signed by the Contractor and the University.

IN WITNESS WHEREOF, the parties have executed this Contract by their duly authorized officer, agents or official on the day and year first above written.

**CONTRACTOR**

\_\_\_\_\_  
Witness

\_\_\_\_\_  
Corporate Officer or Authorized Agent

\_\_\_\_\_  
Date

\_\_\_\_\_  
Printed Name & Title

**TOWSON UNIVERSITY**

\_\_\_\_\_  
Witness

\_\_\_\_\_  
Authorized Agent

\_\_\_\_\_  
Date

\_\_\_\_\_  
Printed Name & Title



Company Name: \_\_\_\_\_

Date of Incorporation: \_\_\_\_\_ State of Incorporation: \_\_\_\_\_

Type of Work Performed:

Number of Years in Business: \_\_\_\_\_

Other or former names under which your organization has operated: \_\_\_\_\_

Type of Organization (e.g., Corp., Partnership, Individual, Joint Venture): \_\_\_\_\_

Name of Principal(s) and Title(s):

Brief History of the Company:

Total Number of Employees: \_\_\_\_\_

Number of Field Employees (Excluding Supervisory): \_\_\_\_\_

Number of Field Supervisory Personnel: \_\_\_\_\_

Number of Office Personnel (Excluding Supervisory): \_\_\_\_\_

Number of Office Supervisory Personnel: \_\_\_\_\_

Bonding Co.: \_\_\_\_\_ Bonding Capacity: \_\_\_\_\_

Proposer: \_\_\_\_\_

Project Name: \_\_\_\_\_

Project Dollar Size: \_\_\_\_\_

Start Date: \_\_\_\_\_

Completion Date: \_\_\_\_\_

Client/Customer: \_\_\_\_\_

Address: \_\_\_\_\_

Contact Person \_\_\_\_\_

Telephone: \_\_\_\_\_

Email: \_\_\_\_\_

Project Manager: \_\_\_\_\_

Description of the Project:

Similarities Between this Project and TU Project:

Bond No. \_\_\_\_\_

**KNOW ALL MEN BY THESE PRESENTS**, that we (Bidding Company), \_\_\_\_\_, as Principal, hereinafter called the Principal, and (Bonding Company) \_\_\_\_\_, a corporation duly organized under the laws of the State of \_\_\_\_\_, as Surety, hereinafter called the Surety, are held and firmly bound unto the State of Maryland, hereinafter called "State," for the sum of: \_\_\_\_\_ Dollars (or \$ \_\_\_\_\_), for the payment of which sum, the said Principal and the said Surety bind ourselves, our heirs, executors, administrators, successors and assigns, jointly and severally, firmly by these presents.

WHEREAS, the Principal has submitted a bid for (Identify Project by Number & Brief Description): \_\_\_\_\_

**NOW, THEREFORE**, if the Principal, upon acceptance by the State of its bid identified above, within the period specified therein for acceptance (ninety (90) days, if no period is specified), shall execute such further contractual documents, if any, and give such bond(s) as may be required by the terms of the bid as accepted within the time specified (ten (10) days if no period is specified) after receipt of the forms, or in the event of failure so to execute such further contractual documents and give such bonds, if the Principal shall pay the State the difference not to exceed the penalty hereof between the amount specified in the Principal's bid and such larger amount for which the State may in good faith contract with another party to perform the work covered by said bid, then the above obligation shall be void and of no effect.

The Surety executing this instrument hereby agrees that its obligation shall not be impaired by any extension(s) of the time for acceptance of the bid that the Principal may grant to the State, notice of which extension(s) to the Surety being hereby waived; provided that such waiver of notice shall apply only with respect to extensions aggregating not more than ninety (90) calendar days in addition to the period originally allowed for acceptance of the bid.

In Presence of:  
Witness

Individual Principal

\_\_\_\_\_  
(Name)

\_\_\_\_\_ as to

\_\_\_\_\_ (SEAL)

In Presence of:  
Witness

Partnership Principal

\_\_\_\_\_  
(Name)

\_\_\_\_\_ as to

By: \_\_\_\_\_ (SEAL)  
Partner

\_\_\_\_\_ as to

By: \_\_\_\_\_ (SEAL)  
Partner

\_\_\_\_\_ as to

By: \_\_\_\_\_ (SEAL)  
Partner

Attest:

Corporate Principal

\_\_\_\_\_  
(Name of Corporation)

AFFIX

\_\_\_\_\_  
CORPORATE Secretary

By: \_\_\_\_\_  
President

SEAL

Attest:

\_\_\_\_\_  
(Surety)

AFFIX

\_\_\_\_\_  
CORPORATE

By: \_\_\_\_\_  
Attorney-in-fact

SEAL

Bonding Agents Name \_\_\_\_\_

Agent's Address \_\_\_\_\_

\_\_\_\_\_

\_\_\_\_\_

Approved as to form and legal sufficiency this \_\_\_\_\_  
day of \_\_\_\_\_, 20 \_\_\_\_.

\_\_\_\_\_  
Associate University Counsel

Principal

Business Address of Principal

Surety

Obligee

a corporation of the State of \_\_\_\_\_  
and authorized to do business in the State of Maryland

STATE OF MARYLAND  
By and through the following Administration  
\_\_\_\_\_ TOWSON UNIVERSITY \_\_\_\_\_

Penal Sum of Bond (express in words and figures)

Description of Contract

\_\_\_\_\_, 20\_\_\_\_  
Date of Contract

\_\_\_\_\_, 20\_\_\_\_  
Date Bond Executed

Contract Number

KNOW ALL MEN BY THESE PRESENTS, That we, the Principal named above and Surety named above, being authorized to do business in Maryland, and having business addresses as shown above, are held and firmly bound unto the Obligee named above in the Penal Sum of this Performance Bond stated above, for the payment of which Penal Sum we bind ourselves, our heirs, executors, administrators, personal representatives, successors, and assigns, jointly and severally, firmly by these presents. However, where Surety is composed of corporations acting as co-sureties, we, the co-sureties, bind ourselves, our successors and assigns, in such Penal Sum jointly and severally as well as severally only for the purpose of allowing a joint action or actions against any or all of us, and for all other purposes each co-surety binds itself, jointly and severally with the Principal, for the payment of such sum as appears above its name below, but if no limit of liability is indicated, the limit of such liability shall be the full amount of Penal Sum.

WHEREAS, Principal has entered into or will enter into a contract with the State of Maryland, by and through the Administration named above acting for the State of Maryland, which contract is described and dated as shown above, and incorporated herein by reference. The contract and all items incorporated into the contract, together with any and all changes, extensions of time, alterations, modifications, or additions to the contract or to the work to be performed thereunder or to the Plans, Specifications, and Special Provisions, or any of them, or to any other items incorporated into the contract shall hereinafter be referred to as "the Contract."

WHEREAS, it is one of the conditions precedent to the final award of the Contract that these presents be executed. NOW, THEREFORE, during the original term of said Contract, during any extensions thereto that may be granted by the Administration, and during the guarantee and warranty period, if any, required under the Contract, unless otherwise stated therein, this Performance Bond shall remain in full force and effect unless and until the following terms and conditions are met:

1. Principal shall well and truly perform the Contract; and
2. Principal and Surety shall comply with the terms and conditions contained in this Performance Bond.

Whenever Principal shall be declared by the Administration to be in default under the Contract, the Surety may, within 15 days after notice of default from the Administration, notify the Administration of its election to either promptly proceed to remedy the default or promptly proceed to complete the contract in accordance with and subject to its terms and conditions. In the event the Surety does not elect to exercise either of the above stated options, then the Administration thereupon shall have the remaining contract work completed, Surety to remain liable hereunder for all expenses of completion up to but not exceeding the penal sum stated above.

The Surety hereby stipulates and agrees that no change, extension of time, alteration or addition to the terms of the Contract or to the work to be performed thereunder or the Specifications accompanying the same shall in any way affect its obligations on this Performance Bond, and it does hereby waive notice of any such change, extension of time, alteration or addition to the terms of the Contract or to the work or to the Specifications.

This Performance Bond shall be governed by and construed in accordance with the laws of the State of Maryland and any reference herein to Principal or Surety in the singular shall include all entities in the plural who or which are signatories under the Principal or Surety heading below.

IN WITNESS WHEREOF, Principal and Surety have set their hands and seals to this Performance Bond. If any individual is a signatory under the Principal heading below, then each such individual has signed below on his or her own behalf, has set forth below the name of the firm, if any, in whose name he or she is doing business, and has set forth below his or her title as a sole proprietor. If any partnership or joint venture is a signatory under the Principal heading below, then all members of each such partnership or joint venture have signed below, each member has set forth below the name of the partnership or joint venture, and each member has set forth below his or her title as a general partner, limited partner, or member of joint venture, whichever is applicable. If any corporation is a signatory under the Principal or Surety heading

below, then each such corporation has caused the following: the corporation's name to be set forth below, a duly authorized representative of the corporation to affix below the corporation's seal and to attach hereto a notarized corporate resolution or power of attorney authorizing such action, and each such duly authorized representative to sign below and to set forth below his or her title as a representative of the corporation. If any individual acts as a witness to any signature below, then each such individual has signed below and has set forth below his or her title as a witness. All of the above has been done as of the Date of Bond shown above.

In Presence of:  
Witness

Individual Principal

\_\_\_\_\_ as to \_\_\_\_\_ (SEAL)

In Presence of:  
Witness

Co-Partnership Principal

\_\_\_\_\_  
(Name of Co-Partnership)

\_\_\_\_\_ as to By: \_\_\_\_\_ (SEAL)

\_\_\_\_\_ as to By: \_\_\_\_\_ (SEAL)

\_\_\_\_\_ as to By: \_\_\_\_\_ (SEAL)

Corporate Principal

\_\_\_\_\_  
(Name of Corporation)

Attest:

AFFIX

By: \_\_\_\_\_  
President with Title

SEAL

\_\_\_\_\_  
Corporate Secretary

\_\_\_\_\_  
(Surety)

AFFIX

By: \_\_\_\_\_

SEAL

Attest:

(SEAL)

Title: \_\_\_\_\_

\_\_\_\_\_  
Signature

Bonding Agent's Name: \_\_\_\_\_

\_\_\_\_\_  
Business Address of Surety

Agent's Address: \_\_\_\_\_

Approved as to legal form and sufficiency this \_\_\_\_\_ day of \_\_\_\_\_, 20 \_\_\_\_\_.

\_\_\_\_\_  
Director of Procurement

Principal

Business Address of Principal

Surety

Obligee

a corporation of the State of \_\_\_\_\_  
and authorized to do business in the State of Maryland

STATE OF MARYLAND  
By and through the following Administration  
TOWSON UNIVERSITY

Penal Sum of Bond (express in words and figures)

Description of Contract

\_\_\_\_\_, 20\_\_\_\_  
Date of Contract

\_\_\_\_\_, 20\_\_\_\_  
Date Bond Executed

Contract Number

KNOW ALL MEN BY THESE PRESENTS, That we, the Principal named above and Surety named above, being authorized to do business in Maryland, and having business addresses as shown above, are held and firmly bound unto the Obligee named above, for the use and benefit of claimants as hereinafter defined, in the Penal Sum of this Payment Bond stated above, for the payment of which Penal Sum we bind ourselves, our heirs, executors, administrators, personal representatives, successors, and assigns, jointly and severally, firmly by these presents. However, where Surety is composed of corporations acting as co-sureties, we, the co-sureties, bind ourselves, our successors and assigns, in such Penal Sum jointly and severally as well as severally only for the purpose of allowing a joint action or actions against any or all of us, and for all other purposes each co-surety binds itself, jointly and severally with the Principal, for the payment of such sum as appears above its name below, but if no limit of liability is indicated, the limit of such liability shall be the full amount of the Penal Sum.

WHEREAS, Principal has entered into or will enter into a contract with the State, by and through the Administration named above acting for the State of Maryland, which contract is described and dated as shown above, and incorporated herein by reference. The contract and all items incorporated into the contract, together with any and all changes, extensions of time, alterations, modifications, or additions to the contract or to the work to be performed thereunder or to the Plans, Specifications, and Special Provisions, or any of them, or to any other items incorporated into the contract shall hereinafter be referred to as "the Contract."

WHEREAS, it is one of the conditions precedent to the final award of the Contract that these presents be executed. NOW, THEREFORE, the condition of this obligation is such that if the Principal shall promptly make payment to all claimants as hereinafter defined, for all labor and materials furnished, supplied and reasonably required for use in the performance of the Contract, then this obligation shall be null and void; otherwise it shall remain in full force and effect, subject to the following conditions:

1. A claimant is defined to be any and all of those persons supplying labor and materials (including lessors of the equipment to the extent of the fair market value be thereof) to the Principal or its subcontractors and subcontractors in the prosecution of the work provided for in the Contract, entitled to the protection provided by Section 9-113 of the Real Property Article of the Annotated Code of Maryland, as from time to time amended.
2. The above named Principal and Surety hereby jointly and severally agree with the Obligee that every claimant as herein defined, who has not been paid in full may, pursuant to and when in compliance with the provisions of the aforesaid Section 9-113, sue on this Bond for the use of such claimant, prosecute the suit to final judgment for such sum or sums as may be justly due claimant and have execution thereon. The Obligee shall not be liable for the payment of any costs or expenses of any such suit.

The Surety hereby stipulates and agrees that no change, extension of time, alteration or addition to the terms of the Contract or to the work to be performed thereunder or the Specifications accompanying the same shall in any way affect its obligations on this Payment Bond, and it does hereby waive notice of any such change, extension of time, alteration or addition to the terms of the Contract or to the work or to the Specifications.

This Payment Bond shall be governed by and construed in accordance with the laws of the State of Maryland and any reference herein to the Principal or Surety in the singular shall include all entities in the plural who or which are signatories under the Principal or Surety heading below.

IN WITNESS WHEREOF, Principal and Surety have set their hands and seals to this Payment Bond. If any individual is a signatory under the Principal heading below, then each such individual has signed below on his or her own behalf, has set forth below the name of the firm, if any, in whose name he or she is doing business, and has set forth below his or her title as a sole proprietor. If any partnership or joint venture

is a signatory under the Principal heading below, then all members of each such partnership or joint venture have signed below, each member has set forth below the name of the partnership or joint venture, and each member has set forth below his or her title as a general partner, limited partner, or member of joint venture, whichever is applicable. If any corporation is a signatory under the Principal or Surety heading below, then each such corporation has caused the following: the corporation's name to be set forth below, a duly authorized representative of the corporation to affix below the corporation's seal and to attach hereto a notarized corporate resolution or power of attorney authorizing such action, and each such duly authorized representative to sign below and to set forth below his or her title as a representative of the corporation. If any individual acts as a witness to any signature below, then each such individual has signed below and has set forth below his or her title as a witness. All of the above has been done as of the Date of Bond shown above.

In Presence of: \_\_\_\_\_ Individual Principal  
 Witness \_\_\_\_\_ as to \_\_\_\_\_ (SEAL)

In Presence of: \_\_\_\_\_ Co-Partnership Principal  
 Witness \_\_\_\_\_  
 \_\_\_\_\_ (Name of Co-Partnership)  
 \_\_\_\_\_ as to By: \_\_\_\_\_ (SEAL)  
 \_\_\_\_\_ as to By: \_\_\_\_\_ (SEAL)  
 \_\_\_\_\_ as to By: \_\_\_\_\_ (SEAL)

\_\_\_\_\_ Corporate Principal  
 \_\_\_\_\_ (Name of Corporation)  
 Attest: \_\_\_\_\_ AFFIX  
 \_\_\_\_\_ By: \_\_\_\_\_ SEAL  
 Corporate Secretary President with Title

\_\_\_\_\_ (Surety) AFFIX  
 By: \_\_\_\_\_ SEAL  
 Attest: \_\_\_\_\_ (SEAL)  
 Title: \_\_\_\_\_

Signature \_\_\_\_\_  
 Bonding Agent's Name: \_\_\_\_\_ Business Address of Surety  
 Agent's Address: \_\_\_\_\_

Approved as to legal form and sufficiency this \_\_\_\_ day of \_\_\_\_\_, 20 \_\_\_\_.

\_\_\_\_\_  
 Director of Procurement



Name of Bidder (Company): \_\_\_\_\_

Solicitation Number: \_\_\_\_\_

Project Title: \_\_\_\_\_

Due Date: \_\_\_\_\_

**Acknowledgement**

**I hereby acknowledge receipt of the following addenda which have been issued regarding the above referenced solicitation:**

Addendum #1, issue date: \_\_\_\_\_

Addendum #2, issue date: \_\_\_\_\_

Addendum #3, issue date: \_\_\_\_\_

Addendum #4, issue date: \_\_\_\_\_

Addendum #5, issue date: \_\_\_\_\_

Addendum #6, issue date: \_\_\_\_\_

Addendum #7, issue date: \_\_\_\_\_

Addendum #8, issue date: \_\_\_\_\_

Addendum #9, issue date: \_\_\_\_\_

Addendum #10, issue date: \_\_\_\_\_

Addendum #11, issue date: \_\_\_\_\_

\_\_\_\_\_  
**SIGNATURE**

\_\_\_\_\_  
**DATE**

\_\_\_\_\_  
**PRINTED NAME**

\_\_\_\_\_  
**TITLE**

Project Name: \_\_\_\_\_

Project No.: \_\_\_\_\_

Bidder/Offeror Name: \_\_\_\_\_

Key Personnel Name: \_\_\_\_\_

Proposed Position Assigned: \_\_\_\_\_

**1. Educational Background**

Institution	Degree/Diploma/Certification	Major (if any) & Date of Degree

**2. Employment History**

If key personnel have more than three (3) previous employers, provide complete employment history via supplemental page(s) attached to this form.

Employer	Dates of Employment (from/to)	Position Held

**3. Project References**

Furnish reference data for project owners/clients for specific projects to which key personnel were assigned. References from projects listed in §5 of this Exhibit L are preferred.

Contact Person	Company Name	Telephone & Email
Description of Project		

Contact Person	Company Name	Telephone & Email
Description of Project		

Contact Person	Company Name	Telephone & Email
Description of Project		

**4. Achievements/Other Notations** (Optional):

**5. Similar Project/Contract Experience**

List at least three (3) prior projects.

Project Name	Project Value	Completion Dates (from/to)
Key Personnel Role	Client Name	Client Contact (email/phone)
Project Description		

Project Name	Project Value	Completion Dates (from/to)
Key Personnel Role	Client Name	Client Contact (email/phone)
Project Description		

Project Name	Project Value	Completion Dates (from/to)
Key Personnel Role	Client Name	Client Contact (email/phone)
Project Description		

**TUNE**  
MOWING EXHIBIT

03.03.2023

- KEY**
- LAWN
  - MEADOW
  - WETLAND

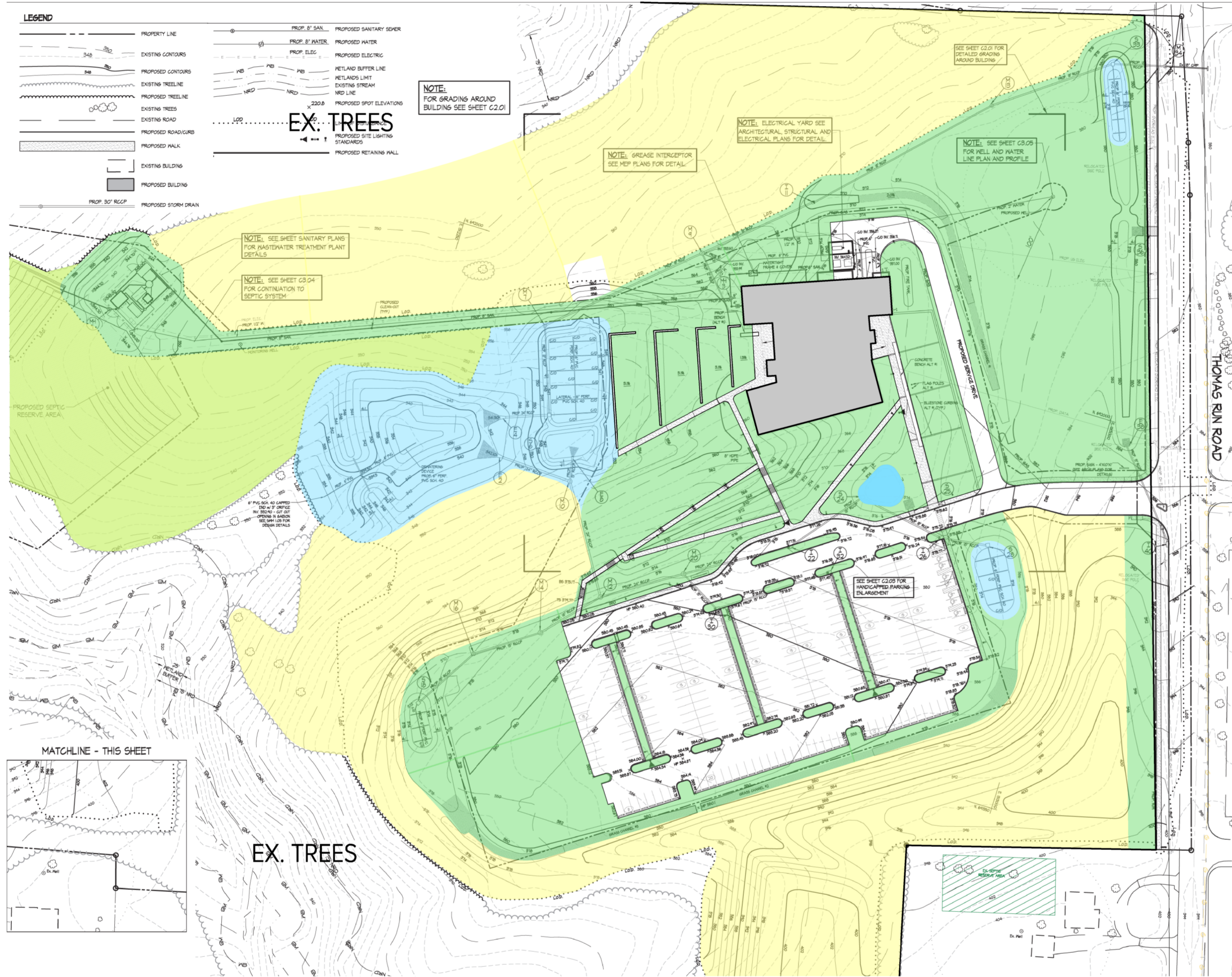

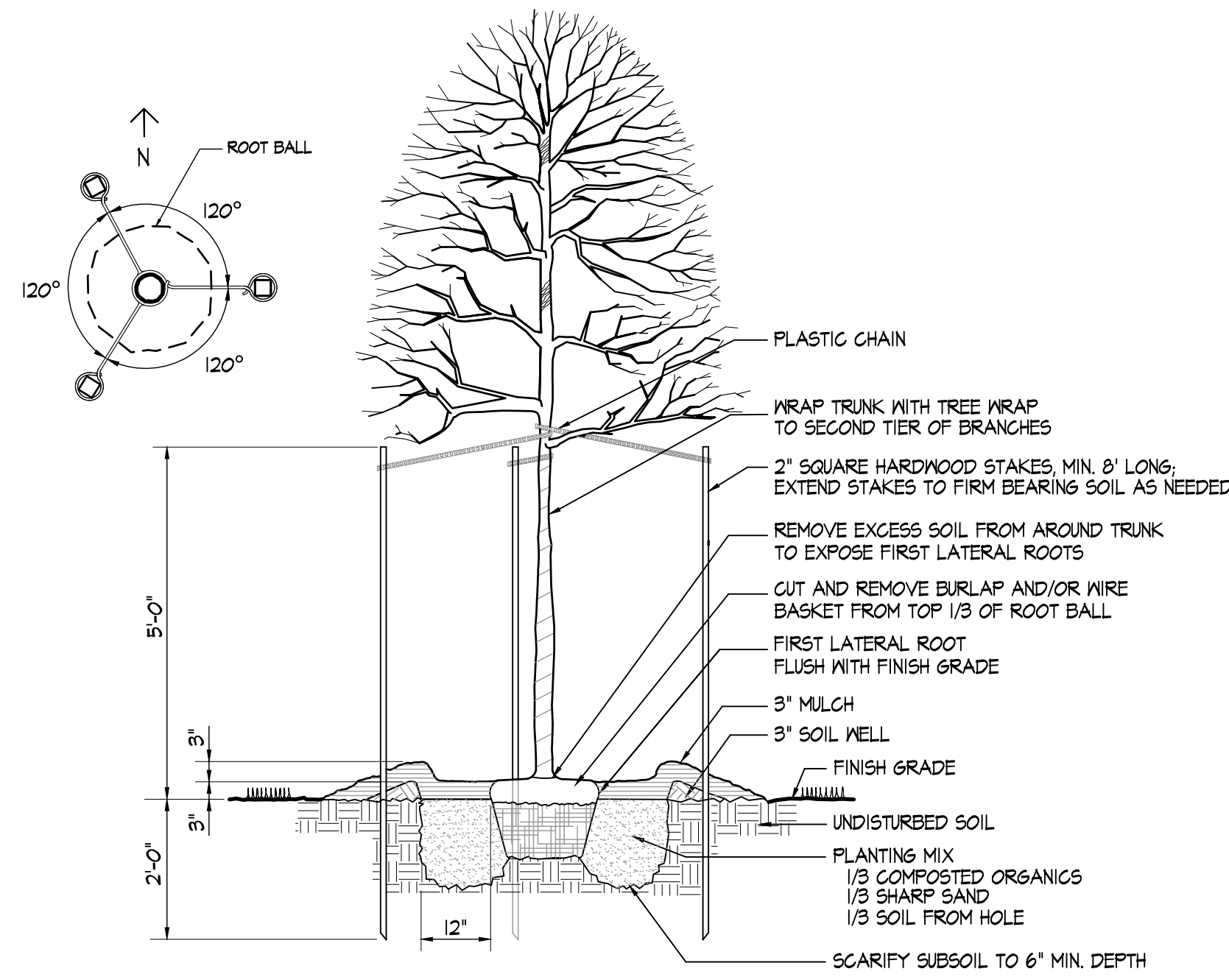

**DECIDUOUS TREE DETAIL**  
NOT TO SCALE

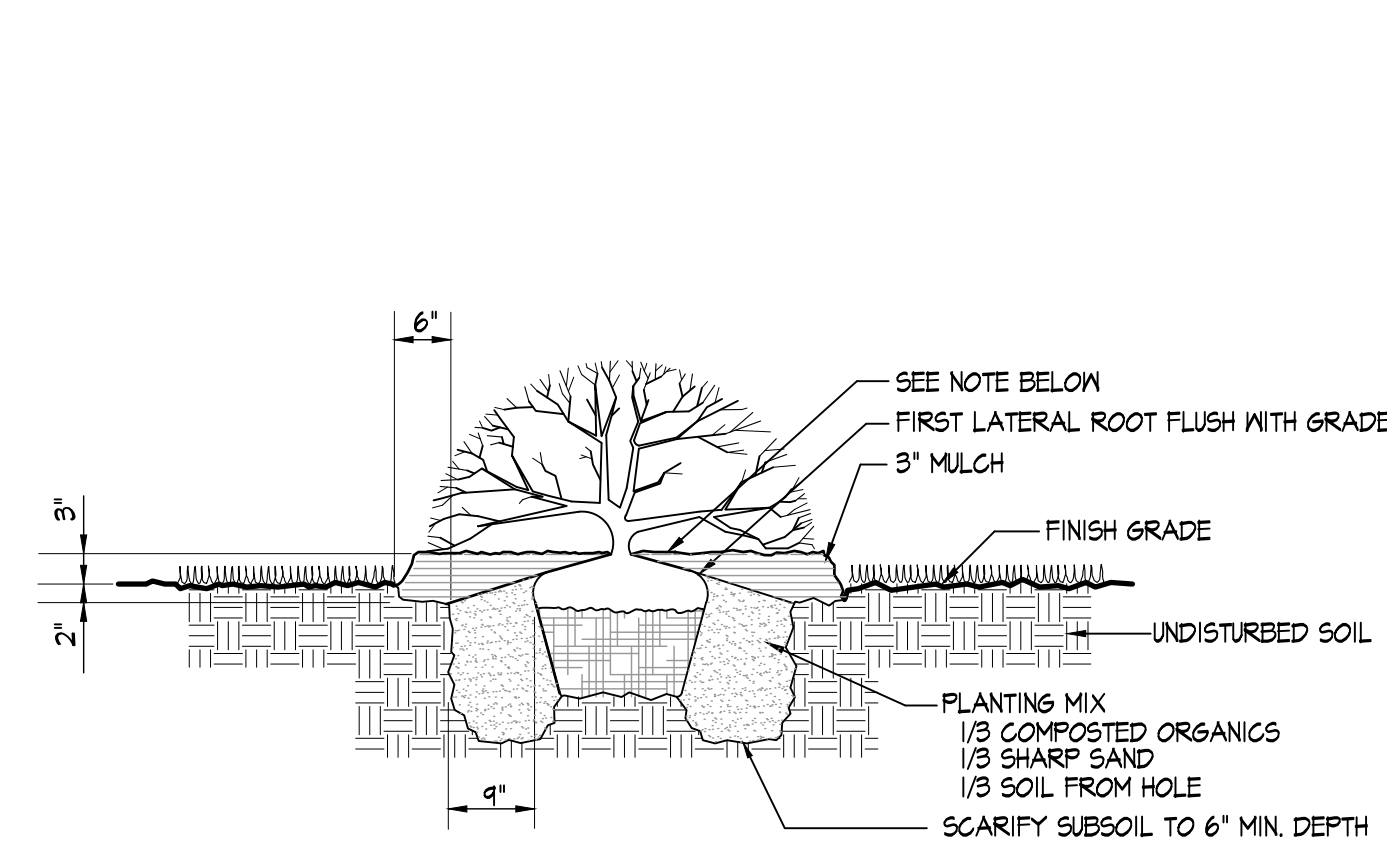

**SHRUB DETAIL**  
NOT TO SCALE

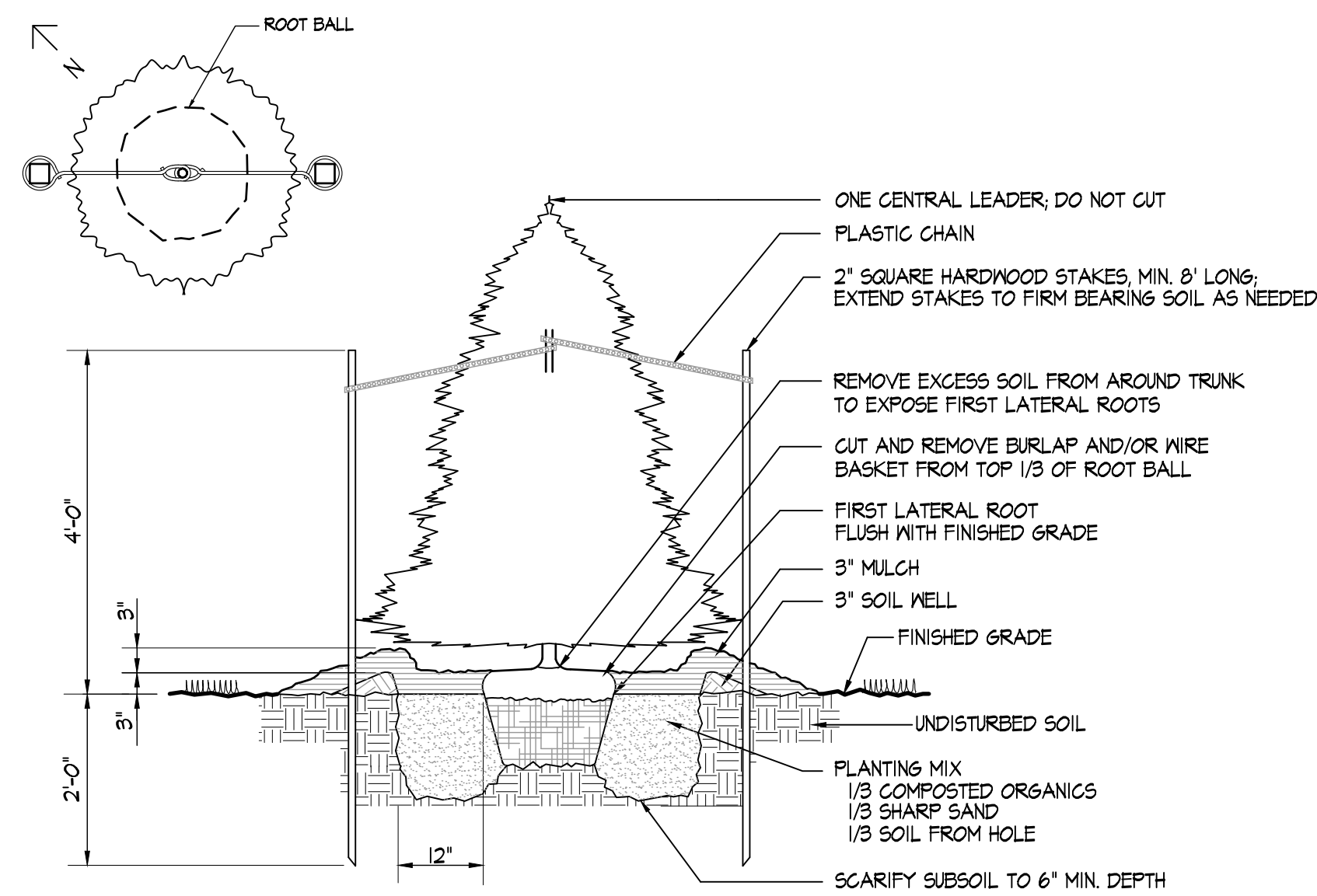

**EVERGREEN TREE DETAIL**  
NOT TO SCALE

**NOTE:**  
FOR ALL CONTAINER-GROWN SHRUBS-  
REMOVE ALL NON-BIODEGRADABLE CONTAINERS AND SCARIFY ROOT BALL BY USING A SHARP  
BLADE AND MAKING 4 TO 5 ONE-INCH CUTS THE LENGTH OF THE ROOT BALL.  
FOR BALLED & BURLAPPED SHRUBS-  
CUT AND REMOVE BURLAP FROM TOP ONE-THIRD OF ROOT BALL.

SEE SHEET C6.01 FOR  
PLANTING PLAN - BASE BID

**PLANT LIST**

KEY	BOTANICAL NAME	COMMON NAME	SIZE	QUANTITY	COMMENTS
<b>DECIDUOUS SHADE TREES</b>					
A6	ACER GRISEM	PAPER BARK MAPLE	3.5' GAL.	12	FULL CROWN / SPECIMEN
AR05	ACER RUBRUM 'OCTOBER GLORY'	OCT. GLORY RED MAPLE	3.5' GAL.	20	FULL CROWN / SPECIMEN
6T1	GLEDITSIA TRIACANTHOS VAR. INERMIS 'SHADEMASTER'	SHADEMASTER THORNLESS HONEYLOCUST	3.5' GAL.	31	FULL CROWN, MATCHING SET
NSY	NYSSA SYLVATICA	BLACK GUM	3.5' GAL.	30	B & B STORED ON SITE
Z56V	ZELKOVA SERRATA 'GREEN VASE'	GREEN VASE ZELKOVA	3.5' GAL.	12	B & B STORED ON SITE

**ORNAMENTAL / FLOWERING TREES**

CCF	CERAS CANADENSIS 'FOREST FANSY'	REDBUD	8' HT.	4	B & B
CM	CORNUS MAS	CORNELIAN CHERRY DOGWOOD	8' HT.	15	FULL CROWN
PSIA	PRUNUS SUBHIRTELLA 'AUTUMNALIS'	HIGAN CHERRY	8' HT.	20	FULL CROWN, MATCHING SET

**EVERGREEN TREES**

CLY	CUPRESSOCYPARIS LEYLANDI	LEYLAND CYPRESS	5-6' HT.	3	# 15 CONT. HEAVY/ONE MAIN LEADER
PIA	PICEA ABIES	NORWAY SPRUCE	8' HT.	30	B & B AND STORED ON SITE
PS	PINUS STROBUS	WHITE PINE	8' HT.	28	B & B AND STORED ON SITE

**KEY**

SEED MIXES	QUANTITY	COMMENTS
ERNMX 153 - SHOWY NORTHEAST NATIVE WILDFLOWER MIX - ERNMX SEED MIX 153 OR APPROVED EQUAL	14.1 AC.	TO BE APPLIED PER MANUFACTURER SPECIFICATIONS
ERNMX 127 - RETENTION BASIN FLOOR SEEDING - ERNMX SEED MIX 127 OR APPROVED EQUAL	1.3 AC.	TO BE APPLIED PER MANUFACTURER SPECIFICATIONS

www.ernstseed.com

<b>MEADOW</b>	ERNMX 153 - SHOWY NORTHEAST NATIVE WILDFLOWER MIX ERNMX 153 OR APPROVED EQUAL www.ernstseed.com	<b>ERNMX 127</b>	ERNMX 127 - RETENTION BASIN FLOOR SEEDING ERNMX 127 OR APPROVED EQUAL www.ernstseed.com
---------------	---	------------------	---

**MEADOW INSTALLATION NOTES:**

- CONTACT THE MANUFACTURER FOR DETAILED SOIL PREPARATION AND SEED SPREADING RATES.
- SOIL PREPARATION:  
TEST EXISTING SOIL IDEAL SOIL PH SHOULD BE BETWEEN 6.0-7.0. AMEND SOIL WITH LIME OR FERTILIZER AS THE REQUIRED BY THE TEST TO ACHIEVE CORRECT PH LEVELS.  
AREAS CHOSEN TO BE SEEDDED MUST BE CLEARED OF ALL VEGETATION. THE USE OF A HERBICIDE FOLLOWED BY ROTOTILLING IS RECOMMENDED. A SECOND ROUND OF HERBICIDE AND

SEED APPLICATION MAY TAKE PLACE FROM SEPT. 15 - OCT. 31 (FALL) MARCH 15 - APRIL 31 (SPRINGS).

**GENERAL NOTES**

- TREES ARE NOT PERMITTED WITHIN TEN (10) FEET OF PUBLIC UTILITIES.
- ALL REQUIRED LANDSCAPE MATERIAL INDICATED ON APPROVED PLANS WILL BE REQUIRED THROUGH THE LIFE OF THE PROJECT AND MUST BE REPLACED IF REMOVED OR DEAD AFTER IMPLEMENTATION BY THE PROPERTY OWNER.
- NO PLANT SUBSTITUTIONS, TYPE, SIZE, OR QUANTITY DEVIATIONS FROM THE APPROVED LANDSCAPE OR BUFFER PLANS SHALL BE MADE WITHOUT PRIOR APPROVAL FROM THE HARFORD COUNTY DEPARTMENT OF PLANNING AND ZONING.

**LANDSCAPE NOTES:**

- QUANTITIES SHOWN ON THE PLANT LIST ARE ESTIMATES ONLY; THE CONTRACTOR IS REQUIRED TO INSTALL THE QUANTITIES LABELED IN PLAN VIEW. CONTRACTOR SHALL NOTIFY SITE RESOURCES OF ANY DISCREPANCY BETWEEN THE QUANTITIES LISTED IN THE CHART AND QUANTITIES SHOWN IN PLAN VIEW.
- PLANT MATERIAL SUBSTITUTIONS ARE SUBJECT TO APPROVAL BY THE OWNER'S REPRESENTATIVE.
- LOCATIONS OF ALL PLANT MATERIAL SHALL BE STAKED FOR APPROVAL BY THE OWNER'S REPRESENTATIVE. OWNER RESERVES THE RIGHT TO ADJUST STAKEOUT LOCATIONS.
- ALL SHRUBS AND GROUND COVER SHALL BE PLANTED IN CONTINUOUS PREPARED BEDS, MULCHED WITH COMPOSTED HARDWOOD MULCH AS DETAILED AND SPECIFIED.
- PLANTING BEDS SHALL HAVE POSITIVE DRAINAGE WITH A MINIMUM 2 PERCENT SLOPE.
- CONTRACTOR SHALL VERIFY ACCURACY OF BASE INFORMATION AND EXISTING CONDITIONS IN THE FIELD TO HIS OWN SATISFACTION. BID SHALL BE BASED ON ACTUAL SITE CONDITIONS. NO EXTRA SHALL BE MADE FOR WORK ARISING FROM SITE CONDITIONS DIFFERING FROM THOSE INDICATED ON DRAWINGS AND SPECIFICATIONS.
- THE CONTRACTOR SHALL NOTIFY MISS UTILITY AT 1-800-251-1111 A MINIMUM OF TWO WORKING DAYS PRIOR TO BEGINNING PLANTING AND CONSTRUCTION.
- DAMAGE TO EXISTING CONDITIONS AND UTILITIES SHALL BE REPAIRED AND RESTORED AT THE EXPENSE OF THE CONTRACTOR.
- ALL PLANT MATERIAL SHALL BE NURSERY GROWN AND SHALL CONFORM TO AMERICAN ASSOCIATION OF NURSERYMEN, INC. STANDARDS.
- ALL PLANTING PROCEDURES SHALL CONFORM TO THE LATEST EDITION OF LANDSCAPE CONTRACTOR ASSOCIATION GUIDELINES FOR THE BALTIMORE/WASHINGTON METROPOLITAN AREA.

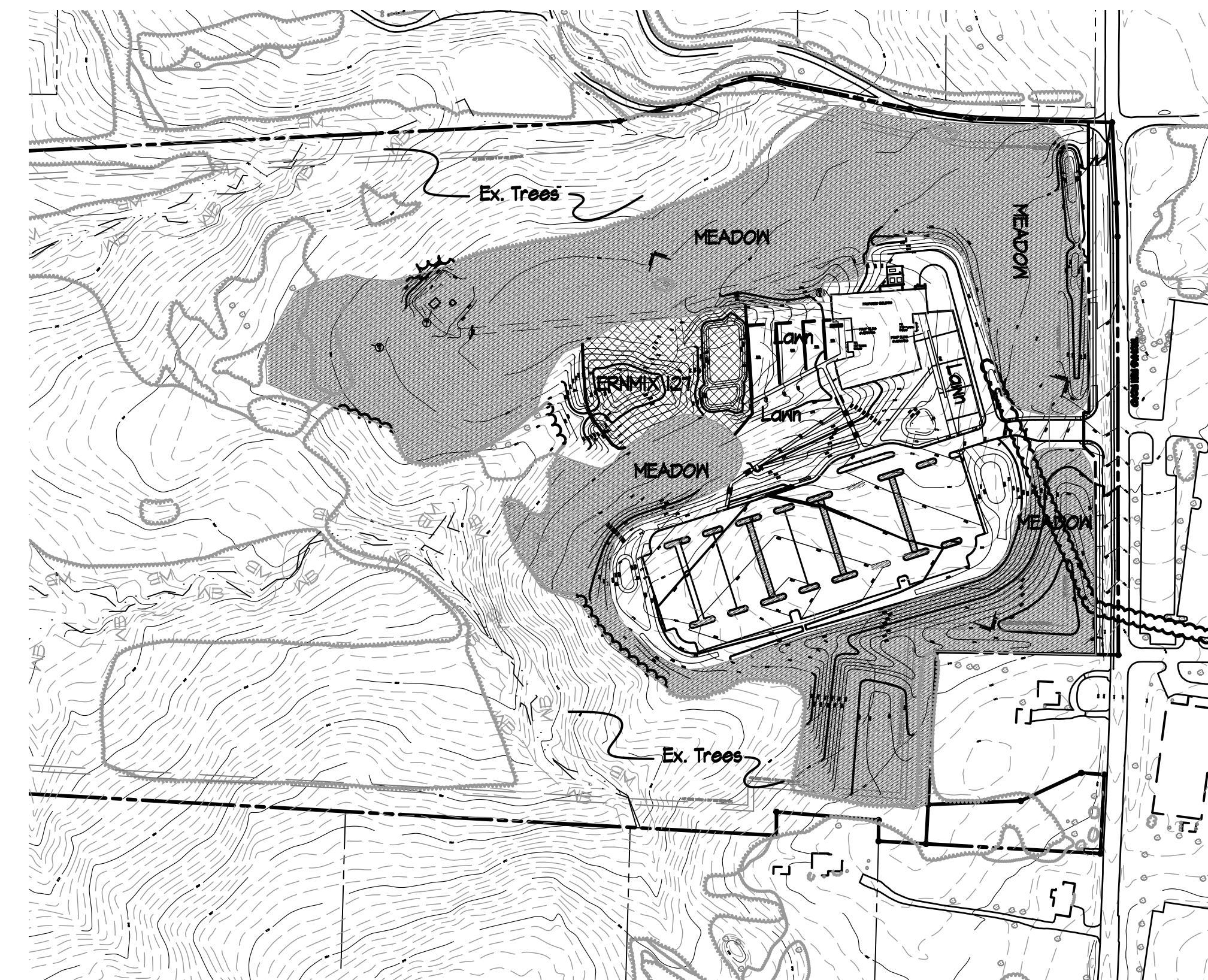

**MEADOW / LAWN SEED MIX INSERT**

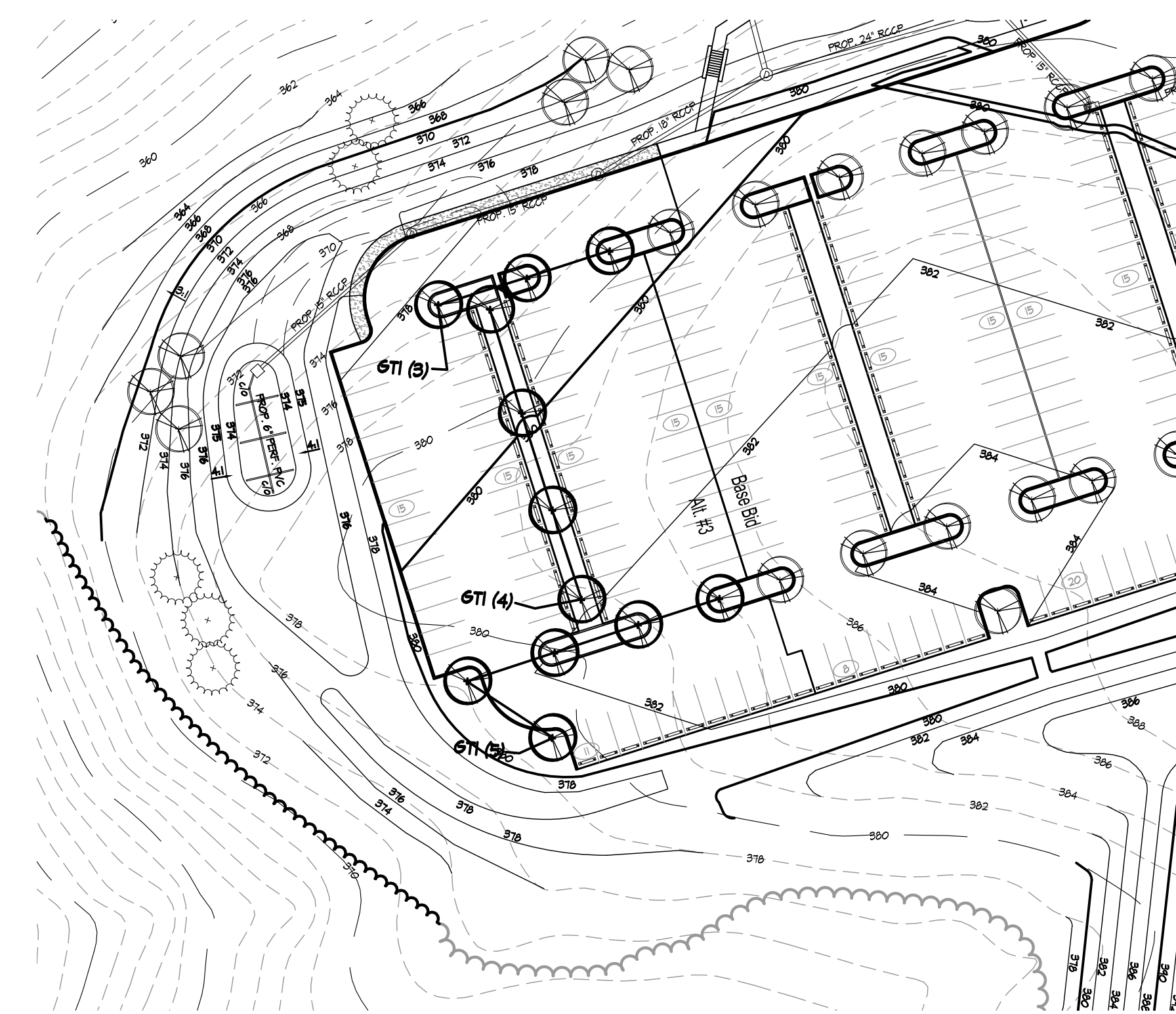
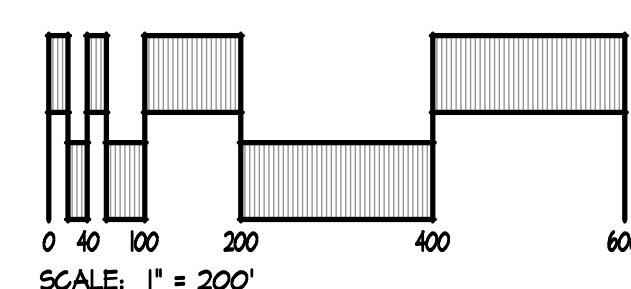

**PLANTING PLAN - ALTERNATE #3**

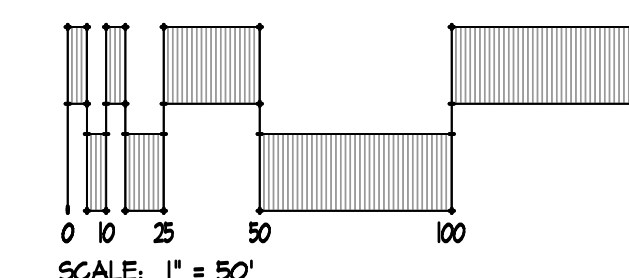
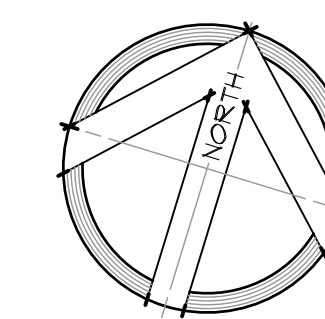

**ALTERNATE PLANT LIST**

KEY	BOTANICAL NAME	COMMON NAME	SIZE	QUANTITY	COMMENTS
<b>DECIDUOUS SHADE TREES</b>					
6T1	GLEDITSIA TRIACANTHOS VAR. INERMIS 'SHADEMASTER'	SHADEMASTER THORNLESS HONEYLOCUST	3.5' GAL.	12	FULL CROWN, MATCHING SET

**PROTECTIVE MEASURE STATEMENT**

I hereby agree to take protective measures in accordance with section 267-29 of the Harford County Code and also agree to replace trees and vegetation should any removal or death occur before, during or after construction.

Owner/Developer \_\_\_\_\_

Date \_\_\_\_\_

RECORD DRAWINGS

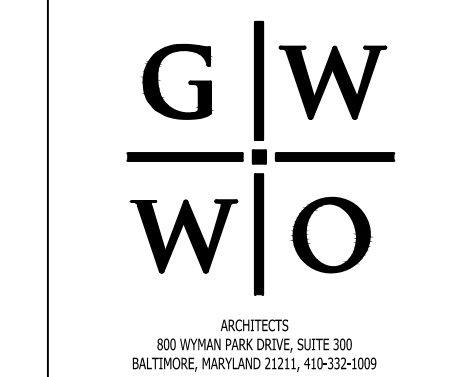

© 2012 G/W/O INC.

PROFESSIONAL CERTIFICATION  
I HEREBY CERTIFY THAT THESE DOCUMENTS WERE PREPARED OR APPROVED BY ME AND THAT I AM A DULY LICENSED PROFESSIONAL ENGINEER UNDER THE LAWS OF THE STATE OF MARYLAND, LICENSE NO. 19489, EXPIRATION DATE: 09/30/15.

Revisions:

No.	Date	Description
1	9/11/2016	RECORD DRAWINGS

**TOWSON  
ACADEMIC BUILDING AT  
HARFORD  
COMMUNITY COLLEGE**

Job No.	0926	Drawn
Scale	AS SHOWN	Checked
Date	MAY 11, 2016	Approved
Drawing Title	Planting Details & Notes	Drawing Number

**L2.01**

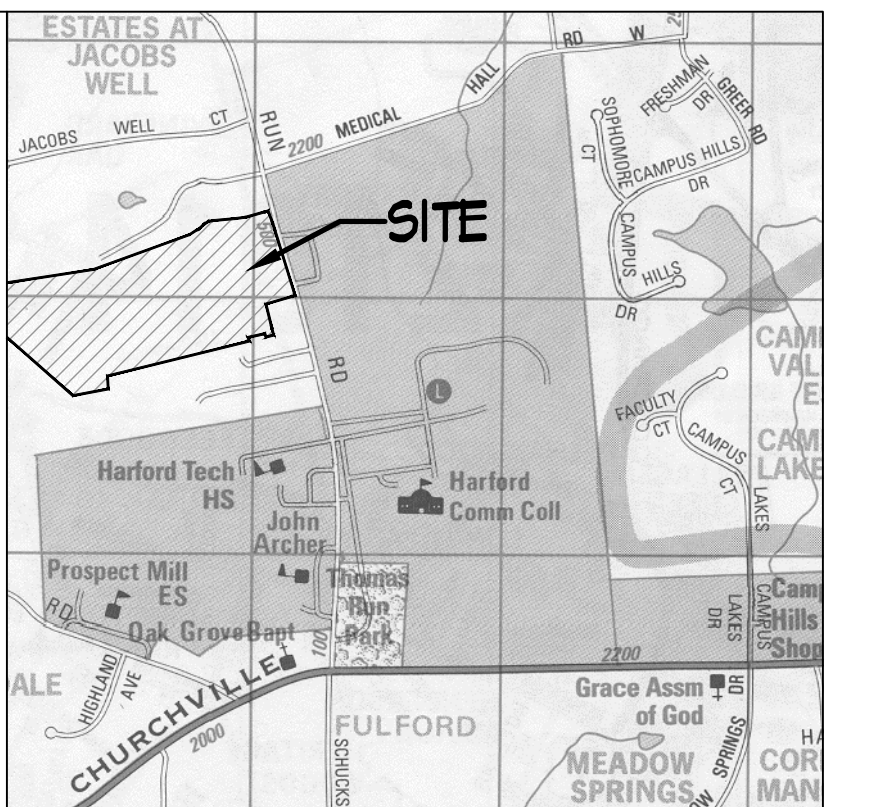
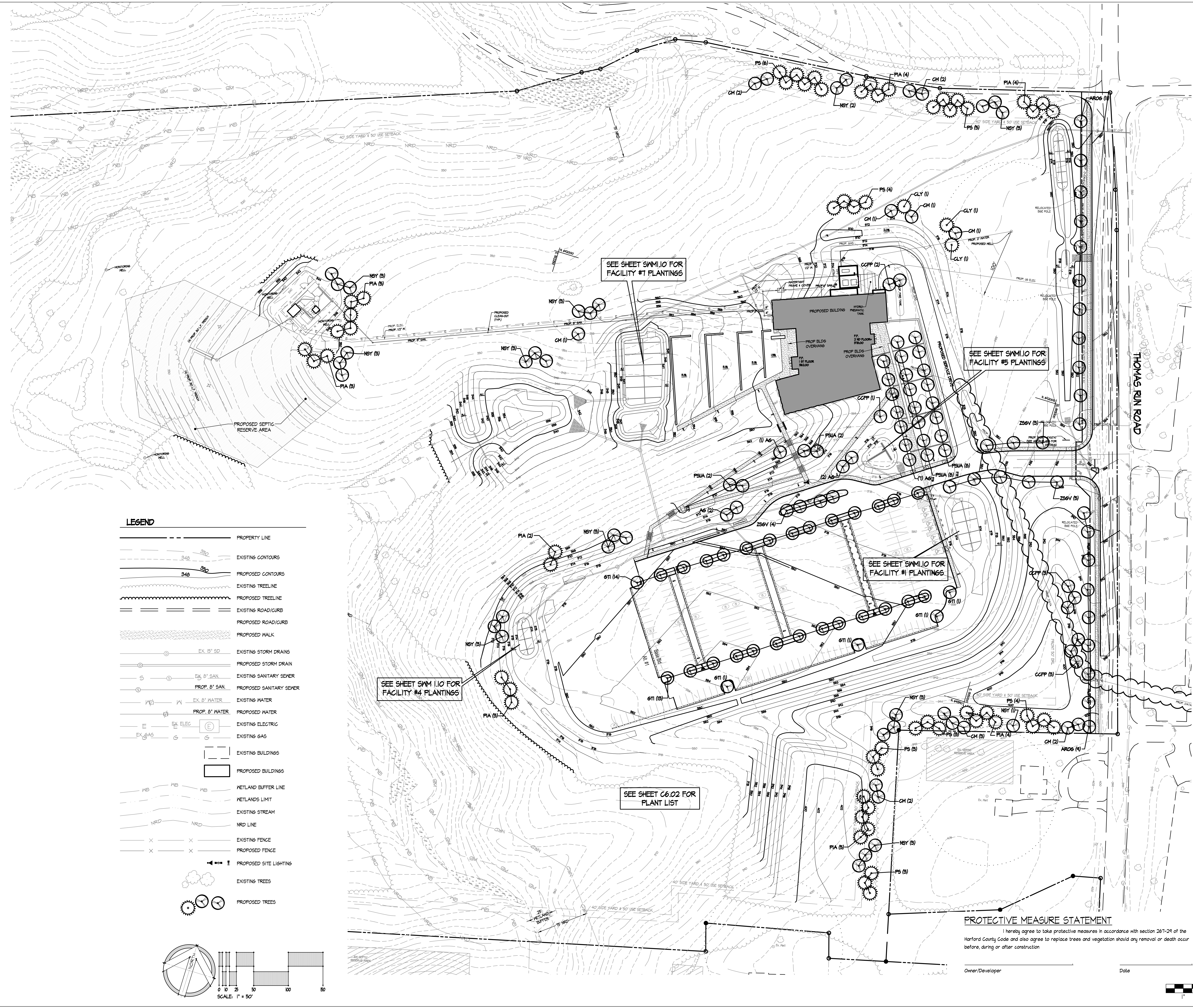

VICINITY MAP 1"=2000'

- SITE DATA:**
- Owner / Developer / Applicant Information and Address:  
Harford Community College  
401 Thomas Run Road  
Bel Air, MD 21015-1648
  - Contact:  
Stephen P. Garay  
Capital Projects Coordinator  
(410) 836-4156 x-156
  - Property Information:  
Election District: 3rd  
Tax Map: 42 Parcel 6 and 256  
Tax Account Number: 0281614 028175
  - Site Address:  
510 Thomas Run Road  
Bel Air, MD 21015-1648
  - Zoning: AS  
Watershed: Lower Susquehanna River
  - Total Site Area: 112.20 ac +/-

- LANDSCAPE CALCULATIONS:**
- STREET TREES:  
LARGE TREE/40 LF  
425 LF OF ROAD = 23 REQUIRED TREES
- PARKING LOT INTERIOR LANDSCAPING:  
SHADE TREE/10 PARKING SPACES  
320 SPACES = 32 REQUIRED TREES
- PARKING LOT PERIMETER LANDSCAPING:  
3' HIGH VISUAL RELIEF, 5' WIDE BUFFER STRIP ABUTTING PUBLIC RIGHT-OF-WAY  
6' HIGH VISUAL RELIEF, ABUTTING ADJACENT PROPERTY
- TOTAL LARGE TREES REQUIRED: 55  
TOTAL LARGE TREES PROVIDED: 45 (INCLUDES THOSE IN RESIDENTIAL BUFFERS)

**LEGEND**

	PROPERTY LINE
	EXISTING CONTOURS
	PROPOSED CONTOURS
	EXISTING TREELINE
	PROPOSED TREELINE
	EXISTING ROAD/CURB
	PROPOSED ROAD/CURB
	PROPOSED WALK
	EXISTING STORM DRAINS
	PROPOSED STORM DRAIN
	EXISTING SANITARY SEWER
	PROPOSED SANITARY SEWER
	EXISTING WATER
	PROPOSED WATER
	EXISTING ELECTRIC
	EXISTING GAS
	EXISTING BUILDINGS
	PROPOSED BUILDINGS
	WETLAND BUFFER LINE
	WETLANDS LIMIT
	EXISTING STREAM
	NRD LINE
	EXISTING FENCE
	PROPOSED FENCE
	PROPOSED SITE LIGHTING
	EXISTING TREES
	PROPOSED TREES

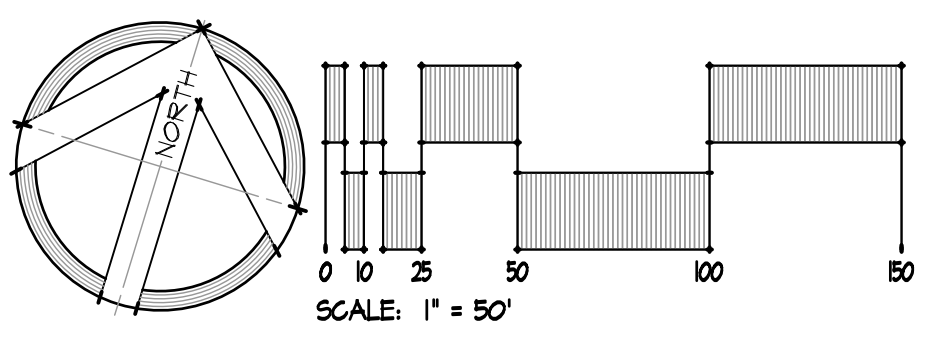

**PROTECTIVE MEASURE STATEMENT**

I hereby agree to take protective measures in accordance with section 267-29 of the Harford County Code and also agree to replace trees and vegetation should any removal or death occur before, during or after construction.

Owner/Developer \_\_\_\_\_ Date \_\_\_\_\_

**RECORD DRAWINGS**

**SITE RESOURCES**  
INCORPORATED  
Comprehensive Land Planning & Site Design Services  
14155 Jermantown Pike • Pikesville, Maryland 21113  
(410) 883-3388 • Fax (410) 883-3389

**G|W|O**  
ARCHITECTS  
800 WYOMING AVENUE, SUITE 300  
BALTIMORE, MARYLAND 21201, 709.223.0099  
© 2012 G|W|O INC.

PROFESSIONAL CERTIFICATION  
I HEREBY CERTIFY THAT THESE DOCUMENTS WERE PREPARED OR APPROVED BY ME AND THAT I AM A DULY LICENSED PROFESSIONAL ENGINEER UNDER THE LAWS OF THE STATE OF MARYLAND, LICENSE NO. 18489, EXPIRATION DATE: 05/31/15.

Revisions:

No.	Date	Description
1	9/11/2016	RECORD DRAWINGS

**TOWSON  
ACADEMIC BUILDING AT  
HARFORD  
COMMUNITY COLLEGE**

Job No.	0926	Drawn
Scale	AS SHOWN	Checked
Date	MAY 11, 2016	Approved
Drawing Title	Planting Plan	Drawing Number

**L1.01**

Bidder's Name: \_\_\_\_\_  
 Project Title: Comprehensive Grounds Maintenance  
 Project Number: TU-2412- SBR

**Failure to properly complete each blank or any alterations/changes made to this bid form may be cause for rejection of this bid/proposal.**

Having carefully examined the solicitation documents for the above referenced project and Addenda Number(s) \_\_\_\_\_ being collectively referred to as the Contract Documents, and having received clarification on all items of conflict or upon which any doubt arose, the undersigned proposes to furnish all labor materials, and equipment required by said documents for the entire work, all in strict accordance with the Contract Documents, for the sum of:

**BASIS OF AWARD (Taken from Bid Worksheet (Excel))**

Basis of Award		\$
	Words	Numbers

**Provide pricing for each requested quantity.**

If the undersigned is notified by the Procurement Officer/Representative of the acceptance of the bid within 90 days after the bid date, Contractor agrees to guarantee the completion of this work as specified in the Contract Documents.

\_\_\_\_\_ Firm License Number (if applicable)      \_\_\_\_\_ Date Issued      \_\_\_\_\_ Place of Issuance

**Certified Small Business:** The undersigned certifies that the Bidder (check applicable box):

- Is NOT a Certified Small Business
- Is a Certified Small business, certified by the Governor's Office of Small, Women and Minority Business Affairs, and assigned the following certification number: \_\_\_\_\_.

The undersigned affirms, and it is a condition precedent to acceptance of this bid, that the bidder has not been a party to any agreement to bid a fixed or uniform price.

Firm Name: \_\_\_\_\_  
 Address: \_\_\_\_\_  
 Phone/Fax No.: \_\_\_\_\_ E-mail Address: \_\_\_\_\_

Federal Tax ID or Social Security No.: \_\_\_\_\_

Signature of Officer or Authorized Agent: \_\_\_\_\_

Printed Name: \_\_\_\_\_

Title: \_\_\_\_\_

Witness: \_\_\_\_\_